

# Autonomous Mine Detection Robot

1st semester project Fall 2015



Robotics B264b

Aalborg University

**Title: Autonomous mine detection****Theme: Mobile robots****Project period: Fall 2015****AALBORG UNIVERSITET**  
STUDENTERRAPPORT**Project group: B264b****Members:**

Andreas Norman

Casper Mariager

Daniel Fischer

Jakob Kristiansen

Ioan-Matei Sarivan

Marius Hensel

Rasmus Kobborg

Sebestyén Nagy

**Supervisor:****Simon Bøgh****Number of pages:****Appendix: On USB with the physical  
copy of the report****Finished 18.12.2015**

*Rapportens indhold er frit tilgængeligt, men offentliggørelse (med kildeangivelse) må kun ske efter aftale med forfatterne.*

*The content of the report is available for everyone, but release (with citation) may only happen in agreement with the authors.*

**Abstract:**

Landmines and improvised explosive devices (IEDs) continue to injure and or kill thousands of people every year as well as hinder development in a variety of countries. The aim of the project is to come up with a solution capable of reducing or eliminating the impact of landmines and IEDs as well as simulate the concept of the solution with a prototype. In order to do so, the problems of Landmines and IEDs are analyzed. The analysis describes the two types of explosives and the impacts of them as well as methods and existing solutions used to cope with landmines and IEDs today. Based on the analysis, the problem is delimited to only landmines and pressure plate IEDs (PPIEDs), and requirements are listed for the solution. Four different solution proposals are then presented, analyzed and finally combined into one final solution. An autonomous, hovercraft based, mine detector is proposed as solution. The hovercraft utilizes a metal detector and ground penetrating radar (GPR) as sensors for detection of landmines and PPIEDs and creates a map with locations of the mines in order to ease the demining process. Finally, by use of the Turtlebot and ROS(Robot Operating System), the project succeeds in creating a prototype simulating core parts of the said solution.

# Signatures

## Robotics - Group B264b

Andreas Flem Norman



Rasmus Vedel Nonboe Kobborg

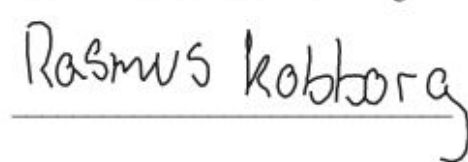

Daniel Kjær Bonde Fischer



Sebestyén Nagy



Ioan-Matei Sarivan

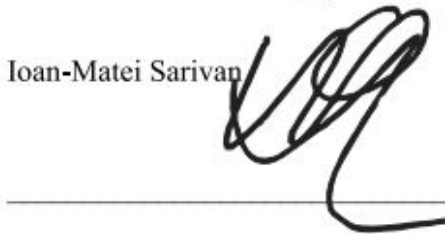

Casper Mariager



Marius Frilund Hensel

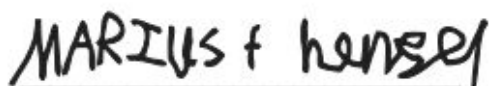

Jakob Kristiansen

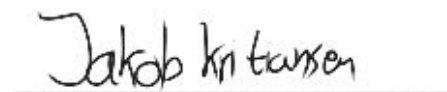

# Table of content

<a href="#">1. Introduction</a>	5
<a href="#">1.2 Initial problem formulation</a>	8
<a href="#">2. Landmines and IEDs</a>	8
<a href="#">2.1 Landmines</a>	8
<a href="#">2.2 IEDs</a>	11
<a href="#">3. Impacts of mines, IEDs and ERW</a>	14
<a href="#">3.1 Casualties</a>	14
<a href="#">3.3 Humanitarian impacts</a>	19
<a href="#">3.4 Economical impacts</a>	19
<a href="#">4. Existing mechanical solutions</a>	22
<a href="#">4.1 Minewolf MW370</a>	22
<a href="#">4.2 FSR Husky</a>	23
<a href="#">5. Methods for detecting mines</a>	25
<a href="#">5.2 Neutron Backscattering</a>	26
<a href="#">5.3 Biological methods</a>	28
<a href="#">5.4 Nuclear Quadrupole Resonance</a>	29
<a href="#">5.5 Ground Penetrating Radar GPR</a>	30
<a href="#">5.6 Summary and comparison of detection methods</a>	32
<a href="#">6. Problem formulation</a>	33
<a href="#">7. Standards and guidelines</a>	33
<a href="#">8. Requirements and delimitations for ideal solution</a>	34
<a href="#">9. Solution proposals</a>	36
<a href="#">9.1 Proposal 1 – Heavyweight</a>	36
<a href="#">9.2 Proposal 2 - cheap and lightweight</a>	38
<a href="#">9.3 Proposal 3 - Drone</a>	40

<a href="#">9.4 Proposal 4 - Hovercraft</a>	43
<a href="#">9.5 The final solution</a>	48
<a href="#">10. Prototype</a>	52
<a href="#">10.1 Hardware components</a>	52
<a href="#">10.2 Concept and operating modes</a>	55
<a href="#">10.3 Software</a>	57
<a href="#">10.4 How to operate the robot</a>	66
<a href="#">10.5 Future work</a>	70
<a href="#">10.6 Conclusion of the prototype</a>	71
<a href="#">11. Final conclusion</a>	72
<a href="#">12. Appendix</a>	73
<a href="#">12.1 Codes</a>	73
<a href="#">13. References and sources</a>	73

# 1. Introduction

*This chapter introduces the problems of landmines and IEDs together with an initial problem formulation.*

## 1.1 Problem introduction

Throughout history, landmines and IEDs (Improvised Explosive Device) have been a major contributor to several humanitarian complications and military challenges. The Chinese were pioneers in the implementation of landmines. In the 13th century they used landmines, specifically as booby traps,<sup>1</sup> in the war against the Mongols.[1] During the world wars the use of anti-personnel and anti-tank mines grew in popularity. As the technologies improved, landmines became an important factor in warfare strategy. The development of landmines escalated in the Second World War with the popularity of minefields rising. The landmines were widely used in the second world war with The Soviet Union as the biggest contributor to the deployment of landmines; planting more than 220 millions landmines.[2]

For the military, IEDs and landmines provide a threat when operating in hostile areas. The problem with IEDs escalated with the wars in Iraq and Afghanistan where a widespread use arose. At the beginning of the Iraq war in March 2003, IEDs were not a known threat to ground forces. However, that would soon change. Already in the summer of 2004, the scale and seriousness of the problem with IEDs was clear and by 2008 the term IED had officially become part of the US military technical language. These improvised explosives have taken a heavy toll on military forces during the wars in both Iraq and Afghanistan. As of August 28th 2007, IEDs were responsible for more than 60 % of all American combat casualties in Iraq [3] and as of November 1st 2015, IEDs have killed a total of 1401 coalition<sup>2</sup> soldiers in Afghanistan making up 50,23 % of the 2789 total hostile fatalities. A hostile fatality is a

---

<sup>1</sup>Oxford Dictionary of English gives the following definition: *An apparently harmless object containing a concealed explosive device designed to detonate when someone touches it.*

<sup>2</sup>Coalition countries include: Albania, Australia, Belgium, Canada, Czech, Denmark, Estonia, Finland, France, Georgia, Germany, Hungary, Italy, Jordan, Latvia, Lithuania, Netherlands, New Zealand, Norway, Poland, Portugal, Romania, South Korea, Slovakia, Spain, Sweden, Turkey, UK and US.[4]

victim of a terrorist activity or a fatality as the result of combat or attack by any force against coalition forces.[4]

This makes IEDs the number one killer of US soldiers in Iraq and also of all coalition soldiers in Afghanistan.[5] During the wars in Iraq and Afghanistan the US military has spent several million dollars towards the development of new technology in the fight against IEDs.[3]

In 2013, a total of 3308 mine/ERW(Explosive Remnants of War) and IED casualties were recorded by the Landmine and Cluster Munition Monitor of which at least 1065 people were killed and 2218 were injured. In 25 cases the outcome of the casualty was unclear. This number of total incidents include both military and civilian casualties and equals to 9 recorded casualties daily in 2013. Not all countries contribute to the record of casualties. The total amount of casualties is therefore in all probability much higher.[6]

Landmines and IEDs are a great threat to civilians living in current or former war zones. In particular, anti-personnel mines pose a danger. 79% of the recorded casualties from landmines and ERW in 2013 were civilians, 46 % of these being children.[6] Children can easily trigger anti-personnel mines since many need as little as 11 pounds of pressure in order to be triggered.[7]

The impact of landmines and IEDs is severe, both humanitarian and economically. The mines and IEDs are often deployed in varying terrain and in large fields making humanitarian demining a difficult task. When IEDs and landmines are planted in fields they are not only hard to detect, they also inhibit potential farm work, thereby hindering farming development until the fields are cleared. Unfortunately, clearing the fields is often economically impossible for most farmers due to the high costs of demining.[8],[9]

The issue with IEDs and landmines has been acknowledged worldwide, which has resulted in the creation of many initiatives and technologies with the purpose of countering the threat from IEDs and landmines.

One of the initiatives is the treaty called “The mine ban treaty”, which was created in 1997 and is currently signed by 80 % of the world's countries. By signing this treaty the countries promise to not use, produce or stockpile mines. Furthermore, they accept to help victims of mines and to assist in the clearance of mine affected areas. The treaty is signed by the

governments of the involved countries, hopefully also encouraging non-governmental groups to obey the treaty.[10]

In addition, there are organizations working specifically with demining. An example of such an organization is UNMAS, which consists of more than 9000 employees. The organization clear leftover minefields for IEDs and landmines, so they may once again be used as farmland. The organization has been going for 26 years and has cleared around 2120 square kilometers of land.[8]

Today's current technologies use different methods for locating mines. The most commonly known method for locating mines is the metal detector. However, the metal detector has its shortcomings when the mines are made from other materials than metal, e.g. plastic or wood. Today's technologies must be able to detect landmines and IEDs of different materials in order to be efficient and reliable. A technology capable of doing so is a ground penetrating radar (GPR). GPR creates the opportunity of finding mines of other materials by emitting radio waves into the ground, but still GPR is not a complete solution to the problem by itself. Some of the current solutions to this problem neglect the detection part and focus only on the disposal part. Heavy machinery is used for this expensive process, mainly by the military.

There are also more alternative methods for finding landmines. One involves using african pouched rats to sniff out the land mines, another involves plants which change color depending on whether there is a presence of explosives or not.

Despite all the current efforts towards a mine free world, over 100 million mines are still buried worldwide. As a consequence, it is estimated that 15,000 - 20,000 people are killed or injured annually.[7]



## 1.2 Initial problem formulation

This report will revolve around the following problem formulation.

*How can a robotic solution assist in demining processes around the world to reduce casualties and hindrance of development due to landmines, IEDs and ERW in current and post-conflict areas?*

# Problem analysis

*The problem analysis will give an insight into what landmines and IEDs are made of, and afterwards a showcasing of the damage and casualties they cause. Finally the chapter will give insight into the current methods for detecting landmines and IEDs.*

## 2. Landmines and IEDs

*The following chapter describes and showcases landmines and different types of these explosive devices. A definition of the term IED will be presented. Due to the wide range of IEDs the chapter focuses on the type of IEDs relevant to this project. Lastly, the purpose of utilizing these types of explosive devices will be discussed.*

### 2.1 Landmines

A landmine is an explosive charge buried underground for the purpose of destruction.

Landmines are mostly set in motion by pressure and are often used to harm humans and destroy vehicles.

Landmines can be split into two main categories: anti-personnel (AP) mines and anti-tank (AT) mines.

### 2.1.1 Anti-personnel mines

anti-personnel mines can then be split into two main categories: Blast mines and fragmentation mines

#### **Blast mines:**

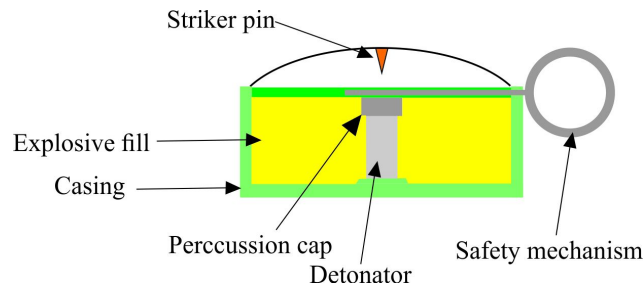

*Figure 2.1 Structure of an AP-blast mine, inspired by source [11].*

Blast mines are typically small cylindrical shaped objects, around the size of 6-14 cm in diameter. In most cases they are buried underground for camouflage (an example of an AP-blast mine can be seen in figure 2.1). There is a minimum pressure needed for the mine to detonate, meaning that small animals, e.g. rats, cannot make the striker pin hit the detonator as seen on figure 2.1. This device relies on the damage caused by the explosion. The mechanism itself is really simple; when the safety pin is removed, the mine is activated, and after pressure is applied to the top, the striker pin hits the percussion cap which triggers the detonator, setting the mine off. It is not necessarily designed to be lethal on impact, but rather leave soldiers with severe wounds making them unable to perform any tasks, including combat, requiring that they are evacuated from the battlefield. In other words, the device is built to do as much damage as possible, in terms of economy and resources. The casing of the mine is often made of plastic instead of metal, making it cheaper to produce, less prone to corrosion and easier to transport due to its light weight. The device also contains a minimal amount of metal, making it harder to find with metal detectors.[11]

## Fragmentation mines:

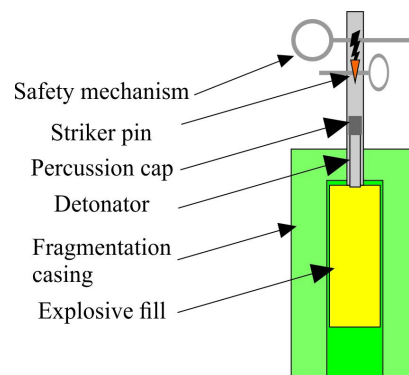

Figure 2.2 Structure of an AP-fragmentation mine, inspired by source [11].

Fragmentation mines rely on metal fragments as their primary source of damage, which are either part of the casing or placed inside the casing. A typically structured fragmentation mine is shown in *Figure 2.2*. A common variation of these mines is tripmines, which are set in motion after the removal of a pin which is connected to a tripwire. Other variations are remotely detonated. The lethal range of such mines is around 15-25 metres, but can cause injuries to targets up to a 100 metres away.[11]

Fragmentation mines can be split into two categories:

**Bounding fragmentation mines:** When initiated, the explosive launches the mine to the height of approximately 1 meter, where the mine then explodes, shooting fragments around in a circle, allowing it to damage several targets at once.[11]

**Directional fragmentation mines:** When initiated, the mine shoots its fragments in one particular direction, making it effective against waves of soldiers when the direction of the target's movement is known. The first mines of this types were remotely detonated. Later, a tripwire was attached to the top, making the activation similar to the bounding fragmentation mines.[11]

### 2.1.2 Anti-tank mines

The anti-personnel mines (AP) and anti-tank mines (AT) are different in size; an AT-mine is bigger than an AP-mine and the AT-mine contains more explosives. Pressure plated AT-mines are most of the time set to require a higher pressure than pressure plated AP-mines. The main difference between the two is that AT-mines are designed to only go off when encountering vehicles e.g. tanks. The reason for making the mines require higher pressure is due to the higher cost of the AT-mine, meaning the mine would fail its purpose when detonated by personnel or wildlife. AT-mines often damages the track wheels on the tank, thereby immobilising the vehicle, but in some cases the mine goes off right under the tank.[11]

## 2.2 IEDs

For a clear understanding of the term IED the following definition presented by Paul Gill, John Horgan & Jeffrey Lovelace in *Studies in Conflict & Terrorism*, will describe the term. The definition is created based upon 29 prior definitions of IEDs, with the purpose of making a new more specific definition.

*“An explosive device is considered an IED when any or all of the following—explosive ingredient, initiation, triggering or detonation mechanism, delivery system—is modified in any respect from its original expressed or intended function. An IED’s components may incorporate any or all of military grade munitions, commercial explosives or homemade explosives. The components and device design may vary in sophistication from simple to complex and IEDs can be used by a variety of both state and non-state actors. Non-state actors can include (but not be limited to) terrorists, insurgents, drug traffickers, criminals and nuisance pranksters.”*[12]

The basic difference between landmines and IEDs is that landmines are crafted to meet certain standards. Landmines are mass produced in factories, while IEDs have common types, but most of them are unique.

As described in the definition above, IEDs come in various types. The most commonly used components for IEDs are shown in *Figure 2.3*. The variation of IEDs makes it possible to have different trigger mechanisms. IEDs can be triggered by the person planting, by a timer

or by a particular action. As an example, the person planting the IED could detonate it with a cell phone, but it could also be triggered by e.g. opening a door.



Figure 2.3 Typical components of an IED (training kit) [13]

As stated, IEDs exist in a huge range of variety, but generally consist of the following components: explosive material, some form of activator, power for the activator and a container.[14] One of the biggest problems regarding IEDs is the fact that every device is unconventionally manufactured, which leads to the possibility of the disarm procedures being unknown by the combat engineers and defuse personnel. Therefore, a standard set of procedures called *Render-Safe Procedures (RSP)* has been created, to better handle the dangerous situation of disarming an IED.[15]

### 2.2.1 PPIEDs

Pressure-plate IEDs (PPIEDs) are some of the most used IEDs since they are relatively cheap to build and easy to plant. PPIEDs are similar to landmines in the way they are camouflaged and activated. A difference between PPIEDs and landmines is that the explosive charge of the bomb can be created of various parts, such as unexploded missiles. PPIEDs are victim activated which makes them an advantageous combat asset. There is therefore no need for the

attacker to be present. The disadvantage is that there is no way to specifically choose a target, so it has a chance to miss the intended target.

PPIEDs can be sorted into categories depending on the triggering mechanism, as it can be victim operated or controlled from a distance.

Victim activated PPIEDs are less reliable, as the attacker has no control after it is planted.

Also a common problem with PPIEDs is due to the time they spend underground - the detonating mechanism might get contaminated, naturally disarming the device.

Radio controlled PPIEDs are more precise, and the chance of accidental detonation is minimised, however it can be made inoperable by a simple signal jammer, therefore some more advanced methods might be needed to make the device functional.[16]

### 2.2.2 Explosive material

The explosive material used in landmines and IEDs are often 2/4/6-Trinitrotoluene, better known as TNT.[11]

TNT is a secondary explosive which means that it needs some kind of primary explosive in order to go off, making it more resistant to shock compared to other explosives. The primary explosive charge is detonated by the triggering mechanism, which then detonates the secondary explosive. [17]

Due to its popularity as an explosive it is estimated that up to 1,000,000 kilograms of TNT is made each year, and because TNT is toxic, it may end up damaging the environment.[18]

*This chapter described landmines of different types and their triggering mechanisms.*

*A description of IEDs in general, together with a deeper introduction to the PPIEDs were presented. After analysing different types of IEDs, some of them seemed less relevant for the project. The following chapter will look into the impacts of mines, IEDs and ERW, and introduce statistics on appearances and casualties regarding these explosive devices.*

### 3. Impacts of mines, IEDs and ERW

*This chapter will investigate the impacts of mines/ERW, describing the direct and indirect impacts of landmines and IEDs. This also covers the challenges of demining. The term mines/ERW includes mines, victim-activated IEDs, explosive remnants of war and cluster munition remnants.*

#### 3.1 Casualties

A lot of countries in the world are still troubled by the problem of landmines, IEDs and other explosive remnants of war (ERW). An annual report by the Landmine and Cluster Munition Monitor shows that casualties per year is slowly decaying every year, and yet the recorded amount of casualties by mines and ERW were 3308 in 2013 alone; of those casualties 1065 were killed and 2218 were injured. In the remaining 25 incidents it was not clear whether the victims died or not.[6] Figure 3.1 illustrates the number of mine/ERW casualties from 1999-2013. It is clear that 2013 was the year with fewest casualties due to mines and ERW. The number of casualties has decreased by 24 % from 2012 to 2013 and the average every day casualties in 2013 (9 casualties per day) makes up 36 % of the average every day casualties in 1999 (25 casualties per day).[6]

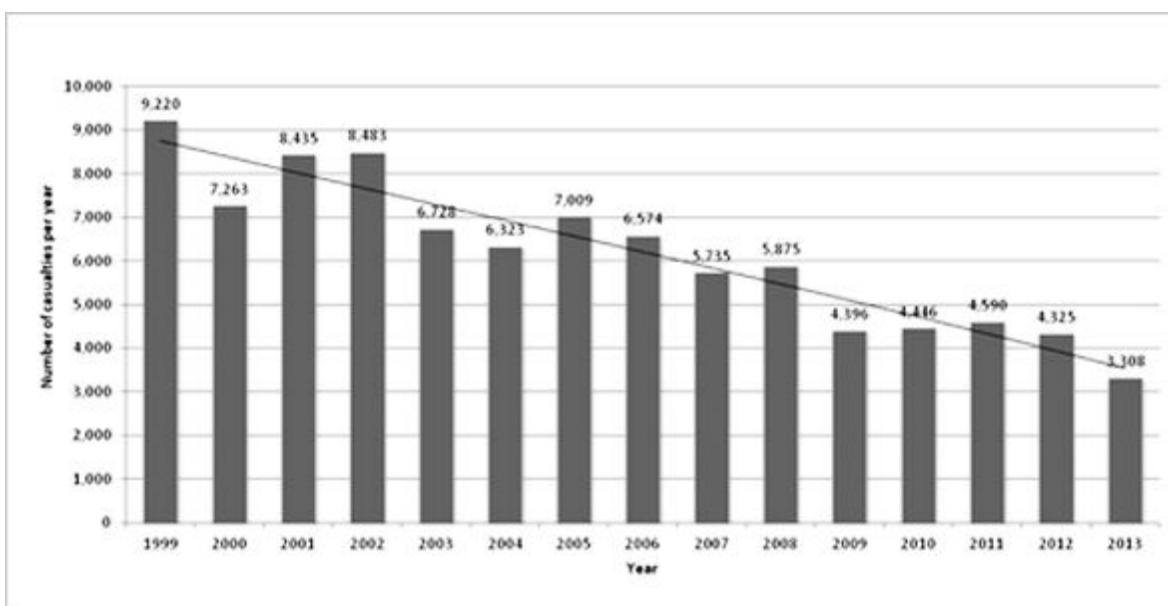

Figure 3.1. Number of casualties per year[6]

The vast majority of all casualties are civilians. Figure 3.2 shows that in 2013, 79 % of all casualties, where the civilian/military status was known, were civilians, 18 % were military and the last 3 % were deminers.[6]

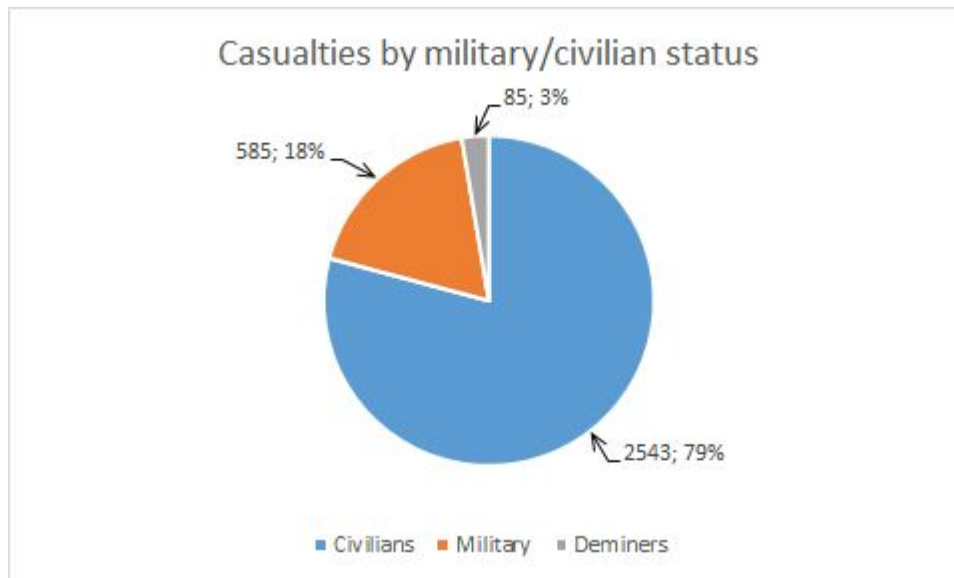

Figure 3.2 Casualties by military/civilian status based on statistics from source [3]

585 military casualties were recorded in 2013. 203 of all military casualties in 2013 occurred in Colombia, 68 were identified in Syria and with 59 incidents Algeria was the country with the third most military casualties in 2013.[6]

A high proportion of all civilian casualties in 2013 was children. 1112 child casualties were recorded in 2013. With 46 % of all casualties being children, 2013 had the second highest proportion of child casualties since 2005.[6]

In 2013, the type of explosive, which caused the casualties, was known in 3034 incidents. Figure 3.3 displays casualties in 2013 and 2012 classified by type of explosive device. 27 % of all casualties were caused by factory-made anti-personnel mines, while 22 % were a result of victim-activated IEDs. In 2012, 25 % of all casualties were caused by factory-made anti-personnel mines, while 31 % was the result of victim-activated IEDs. This means that the number of casualties caused by victim-activated IEDs has decreased by nine percentage points from 2012-2013, while the number of casualties related to factory-made anti-personnel



mines has increased by 2 percentage points from 2012-2013. The number of states where casualties related to victim-activated IEDs occurred dropped from 12 in 2012 to 7 in 2013.

Anti-tank mines caused 212 casualties in 2013. The trend with AT-mine related casualties is that they are declining. Casualties caused by ERW made up 34 % of all casualties in 2013 compared to 31 % in 2012. ERW pose a particular danger towards children. Of all civilian ERW casualties, 72 % were children and close to two-thirds of all child casualties were caused by ERW, whereas only 20 % of all adult casualties were caused by ERW. Figure 3.3 illustrates the number of casualties by type of explosive from 2012-2013.

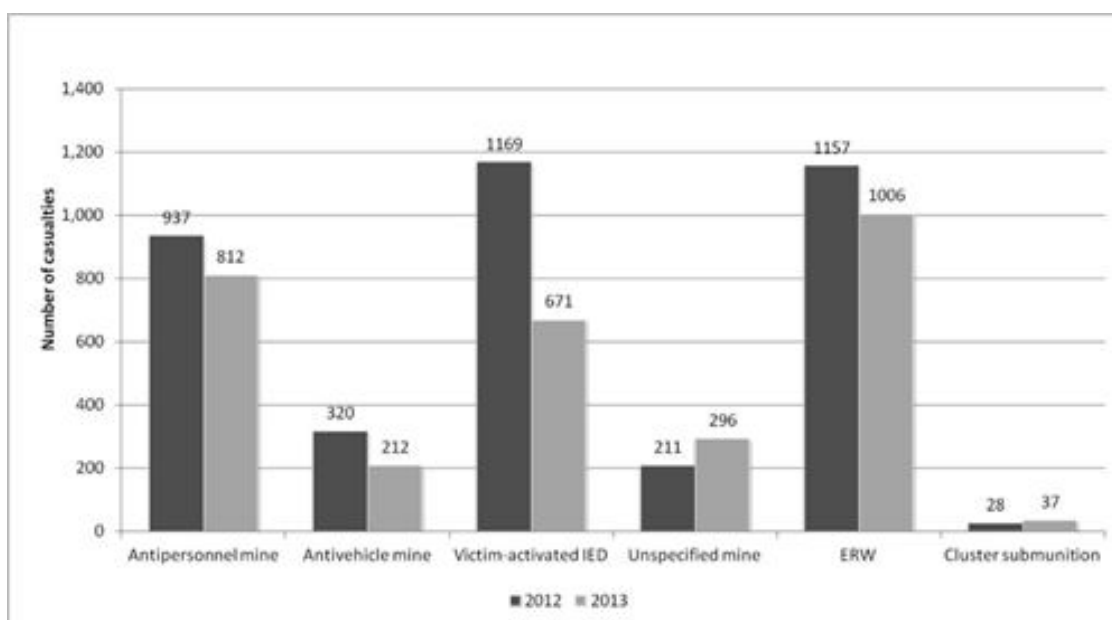

Figure 3.3 Casualties classified by type of explosive in 2012 and 2013.[6]

Since 1999, three countries have been particularly exposed to landmine and ERW casualties. Those countries are Afghanistan, Colombia and Cambodia and together they make up 39 % of all global mine/ERW casualties ever recorded by The Landmine Monitor. An estimate of 10 million landmines were buried in the ground in both Afghanistan and Cambodia in 2011.[7] Figure 3.4 ranks the countries with over 100 mine/ERW related casualties according to total number of casualties in 2013. Afghanistan was, as in all previous years since 1999, the country with most casualties related to landmine and ERW incidents. Countries in the figure written in bold indicates that these countries are part of The Mine Ban Treaty.[6]

Country	Number of casualties
<b>Afghanistan</b>	1050
<b>Colombia</b>	368
Pakistan	219
Syria	201
<b>Iraq</b>	124
<b>Cambodia</b>	111
Iran	107
Myanmar	101

*Figure 3.4 Countries with over 100 casualties ranked by total number of casualties in 2013 [6]*

A significant increase in casualties has been registered in Syria from 2012-2013. Specifically, 63 casualties in 2012 rose to 201 casualties in 2013. This happened due to an increased contamination of mines and ERW in combination with big population movements in 2013. In total, incidents related to landmines, IEDs and ERW were recorded in 55 states and other areas in 2013. This indicates a positive change since the total number of affected states/areas was 62 in 2012 and 72 back in 1992.[6]

## 3.2 Demining

Humanitarian demining is a long process, and it takes many years to scourge a whole country for landmines and IEDs. In the past five years, less than 1000 km<sup>2</sup> were cleared of mines worldwide. Continuing the current demining pace, it will take over 1100 years to remove all landmines.[19] It is estimated that in the time for one landmine to be removed 10-20 mines are laid, making the demining rate 10-20 times slower than the laying rate.[7]

The job of demining can be incredibly dangerous. The Landmine Monitor has recorded 1575 casualties among deminers from 1999 to 2013 giving an average of 105 casualties per year. In 2013, 9 deminers were killed and 76 were injured. Casualties among deminers happened in a total of 11 states in 2013. 68 % of all incidents among deminers in 2013 were identified in three specific countries, namely Iran with 28 incidents, Afghanistan with 18 incidents and Cambodia with 12 incidents.[6]

In addition to the incredible perilous job of the landmine clearance itself, the workers are also facing potential abduction from non-state armed forces e.g. Taliban. In January 2014, 57 deminers from the organization "The HALO Trust" were abducted by the Taliban, luckily they were released a few hours later, but it remains an example that the explosives are not the only danger when demining. In November 2013, two deminers from the organization Handicap International were shot and killed by a resistance group in Mozambique called RENAMO. These episodes show some of the dangers related to demining.[6] The same goes for military demining. If the demining is done manually, the deminers face the danger of being attacked or ambushed by hostile forces. Therefore, safety of the deminers must be a big priority when developing new technologies for demining purposes. Speed is also an important factor in military situations; risk of hostile attacks increases with the time spent on demining.[7]

The problem of mines, IEDs and ERW goes beyond the direct victims which are the men, women and children who are killed or injured. For most of the casualties there is a related family or community, which has to deal with potential new physical, psychological and economic pressures. Also, landmines and PPIEDs does not have to detonate to cause problems. For example, unexploded landmines buried in fields prohibits farming of the land. There is no data on how many people that are indirectly affected by landmines in 2013.[6] However, over the past decades multiple surveys have been conducted to give an insight into how people are indirectly affected by landmines IEDs and ERW.

### 3.3 Humanitarian impacts

The social impacts of landmines in 1995 were investigated by collecting data from 174,489 people living in 32,904 household in the four countries; Afghanistan, Bosnia, Cambodia and Mozambique. The results showed that 6 % of the households had a victim of landmines, a third of these victims died by the landmine encounter. Depending on the country 25 % all the way up to 87 % of the people had their daily activities affected by mines. Having a victim of a landmine in the household impacts the environment in the house in a negative manner. 40 % of the households with victims encountered challenges regarding the gathering of food for the family. For the surviving landmine victims, 25 % had problems with family relationships and 40 % had problems with coworker relationships because of posttraumatic stress syndrome causing difficulties. Not only are the landmines mentally draining for the victims and their families, the landmines also affect the housing situation for some of the families. 7 % of the families informed that they would not be able to return to their house because of the risk of landmines.[20]

### 3.4 Economical impacts

The cost of producing a landmine is roughly between 3\$ and 30\$, whereas the cost for removing them again is significantly higher. The price of removing a single landmine is between 300\$-1000\$, depending on the minefield and the amount of false alarms in the process of detecting the landmines.[7]

In 2013, almost \$446 million were collected from international contributions supporting the mine action, which has decreased from 2012's international support of \$497 million, almost 10 % (\$51 million) less, which is shown in figure 3.5. The highest recipient in 2013 was Afghanistan, who received 72.6 million dollars, more than twice as much as the second highest recipient (Laos PDR received 34.8 million dollars).[6]

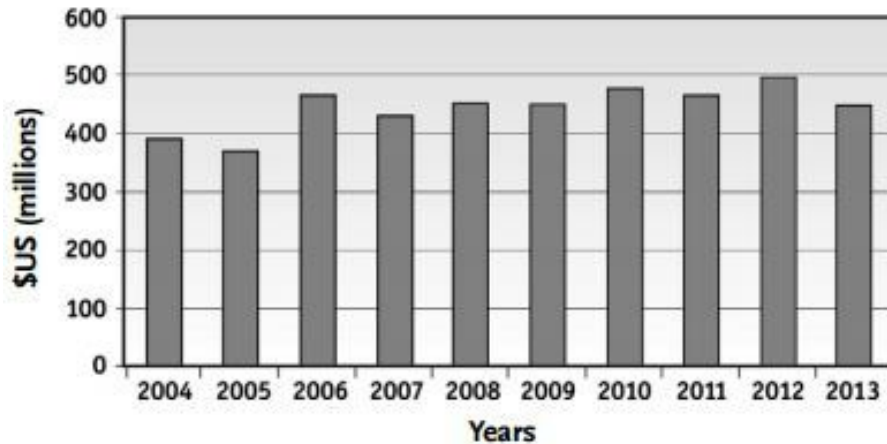

Figure 3.5 International support for mine action.[6]

From figure 3.5 it is clear that hundreds of millions of dollars have been donated internationally as support for mine action every year since 2004. This goes to show that the economic impact of mines/ERW is not limited to the countries with mines/ERW. Other countries are economically affected by the the donations they contribute with. This is an indirect impact of the landmines.

When mines are buried in agricultural fields, farmers will often clear the mines themselves. This often ends with the landmine being triggered, damaging the land and either injuring or killing the farmers. Landmines cause fear in affected communities, even though people may never have seen a mine. This uncertainty of mines, gives the farmers mistrust in the land preventing them from utilizing it. When speaking of landmines, this factor is seldom taken into consideration, even though there is a clear link between landmines on farmland and the economy of the country.[2] Estimations show that the agricultural production would increase immensely in many countries if mines were not a problem. In Afghanistan, for example, it is predicted that the agricultural production would increase with 88-200 %, depending on the region, if the country were to be mine-free.[20]

A lot countries use many resources on technologies to aid in the disposal of landmines and IEDs. In fact The United States Department of Defense have spend over \$15 billion on technologies to aid in the disposal of IEDs. Existing technologies used by militaries are effective in the clearance of landmines and IEDs. However, the problem with these

technologies is the cost. The Talon, which is the most widely used military robot for disposal of landmines and IEDs, costs \$60,000-100,000. 2500 talons have been deployed from 2000 to 2011.[7] In addition, mine resistant ambush protected (MRAP) vehicles used by the military as defense against mines/IEDs cost \$800,000 in average.[3]

*This chapter accounted for the impacts of landmines, IEDs and ERW. It was shown that mines/ERW continue to cause a lot of casualties every year, most of them civilians. The three countries with most casualties in 2013 were Afghanistan, Colombia and Pakistan. The vast majority of all casualties were caused by either anti-personnel mines, victim activated IEDs or ERW and they account for approximately equal amounts of casualties. While militaries have access to effective methods and technologies for demining, these technologies are often expensive. Humanitarian demining is still a slow process and the demining rate of mines is 10-20 times slower than the laying rate. Also, deminers are at great danger. 85 deminers were killed or injured in 2013 and while working they also face danger from non-state armed forces who might abduct or kill the deminers. The impact of landmines extend beyond the direct victims. For example, some families are not able to return to their home in mine-affected areas. In addition, landmines inhibit farm work. Removal of landmines from the fields would increase agricultural production immensely. Lastly, much money is donated to the clearance of mines internationally.*

*Next section will give an insight into already existing solutions capable of detecting and/or disposing mines/ERW.*

## 4. Existing mechanical solutions

*In this chapter an insight in some of the current existing solutions will be presented. The existing solutions will serve as a comparison and inspiration for the robotic solution presented further on into the report. This chapter gives a good overview of some current solutions already on the market.*

### 4.1 Minewolf MW370

The Minewolf MW370 has two attachments; both of them work as a method of brute force. The first attachment is the flail method, which is a rolling pin with chains attached around it. Each chain has a hammer at the end of it. When the rolling pin starts to spin, the hammers will smash into the ground; if a landmine is hit, it detonates. The second attachment is called a tiller. The tiller consists of a rolling pin, which has a lot of small hammers attached to it, so it will plow through the ground, as seen in figure 4.1.



*Figure 4.1 - Minewolf MW370 with a tiller attachment [21]*



*Figure 4.2 The minewolf flail [22]*

Compared to the flail method, the hammers going into the ground are firmly placed on the rolling pin. The tiller, as seen in figure 4.1, is also better at securing that even the smaller anti-personnel mines will be destroyed, whereas the flail method is a better choice when it comes to disposing anti-tank mines, due to its range. The minewolf is capable of clearing up TNT with a size of 15 kg before it harms the machinery. The minewolf MW370 is a brute solution, as it destroys the mines and the earth around it instead of removing the mines safely. The heavy machinery is not capable of operating in all environments, due to it running on tracks. [23],[24],[25]

## 4.2 FSR Husky

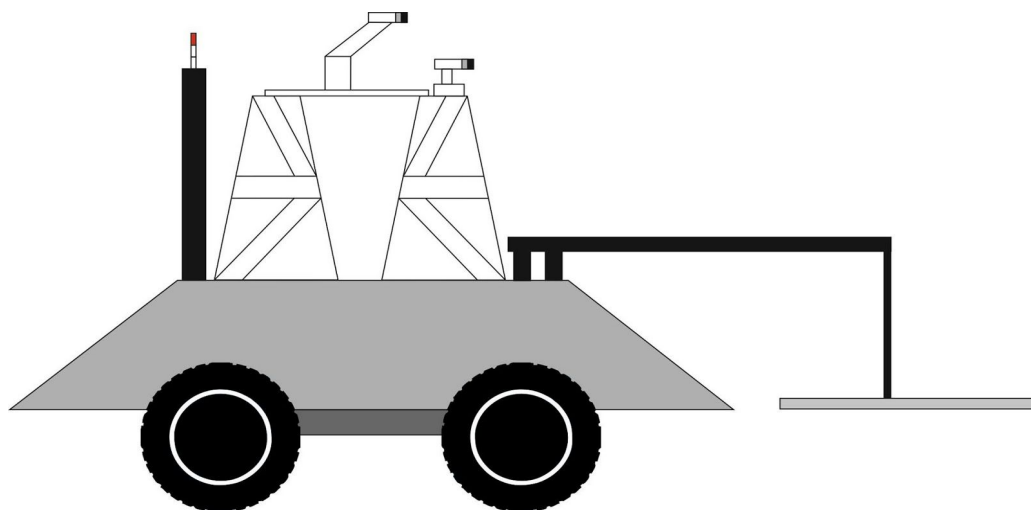

*Figure 4.3 FSR Husky mine-detection robot*



The FSR Husky robot is a machine capable of operating in different kinds of harsh terrain like dirt, sand, snow etc. A sketch of the FSR Husky is shown in figure 4.3.

The robot is constructed on a Clearpath Husky A200 base which makes the design durable. Having a weight of around 50 kilograms and four by four wheel traction makes this landmine detection robot able to get over obstacles easily.

The FSR Husky is equipped with a camera providing images in a real-time. It also has a gyroscope, magnetometer and accelerometer, which provide information about the spatial orientation of the robot.

The detection method consists of a magnetic coil-based sensor attached to an actuator arm. The actuator arm is mounted in front of the robot. This arm is oscillating while the robot is advancing forward. In this way the sensor searches the field in front of the robot for landmines, ensuring that the robot will not pass any explosive charges.

This robot is very simple to operate. The arm in front swipes the ground in order to find possible mines, just like a soldier with a metal detector would do. If required, the robot may be controlled by teleoperation using a joystick[26].

The husky is basically a metal detector on wheels, meaning that the mines still has to be removed when found by human labor. Compared to the Minewolf MW370, the husky does not harm the ground.

*This chapter showcased some of the common existing solution that involve machinery for clearing out mines. There are machineries and devices capable of detecting the mines, but a commonly used method is to detonate the landmine using heavy machinery.*

## 5. Methods for detecting mines

*In this chapter there will be an elaboration and explanation of the current methods used for detecting mines and the efficiency of these, thereby providing a better understanding of existing technologies and methods, before developing a robotic solution. This chapter highlights the advantages and disadvantages of each method by comparing time, cost, accessibility, accuracy and versatility.*

### 5.1 Metal detection

The detection of landmines is a tactical challenge consisting of materials and technologies. Some of the first mines invented were made of wood. The wood landmine was called PMD-6 and was an anti-personnel landmine. They were used in the First World War and afterwards the material of mines changed from wood to metal, allowing for greater damage and impact. Detecting the mines was a demanding task because mines were small and dangerous to remove. The metal detector was a breakthrough in technology, when finding metal mines. The metal detector works by emitting a magnetic field, which is affected by magnetic metals in the ground. When there is a disturbance in the magnetic force, it will emit a sound to the person carrying it, signaling that there is something, which can potentially be a mine. A modern metal detector has a range of around 150 cm[27]. Some landmines only contain metal in the trigger pin of the mine, meaning the sensitivity of the metal detector will have to be increased. An increase in sensitivity may cause the metal detector to respond to other objects containing metal such as bottle caps or shrapnel resulting in false positive signals. It does not detect the gunpowder in the mines, only the metal, meaning everything made out of metal emits the same signal as a mine.[28] An overview of the method's advantages and disadvantages can be found in table 5.1.

	Advantages/disadvantages of the metal detection method	
<b>Price</b>	Cheap	
<b>Detection time</b>	Instantly	
<b>Accessibility</b>	Accessible	
<b>Accuracy</b>		It can generate false alarms
<b>Versatility</b>		Detects only mines made of metal

*Table 5.1 A table of the advantages and disadvantages for metal detectors*

## 5.2 Neutron Backscattering

As technology evolved, landmines were made of different kinds of materials. Landmines can be made of plastic in order to avoid metal detectors. Some methods for detecting these mines could be by the use of radiation and radiography. The method consist of using neutron backscattering, which is used to find hydrogen in objects. Plastic mines contain a high amount of hydrogen, which makes the method applicable (Plastic contains 40-67 % hydrogen and explosives contains 24-35 % hydrogen).[29]

As an example, the PELAN(Pulsed Elemental Analysis with Neutrons)[23] uses a neutron generator to emit neutrons into the ground. The neutrons then send back gamma rays, which hits the receiver of the PELAN, as seen in figures 5.1.

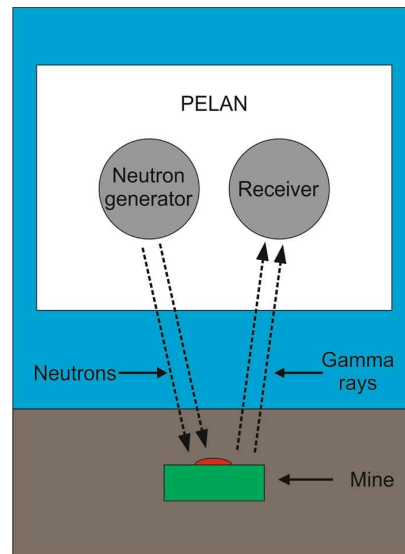

*Figure 5.1 a figure of the PELAN method inspired by source [30]*

The information is then processed by the PELAN, creating an image of the underground, displaying landmines and IEDs.

This method can find both metal and plastic landmines, and works in different kind of weather.[28] If the soil is moist, the detection time will be reduced.[31]

The device weighs 18 kilograms and may be used by a single person. Even though it is a nuclear technology it does not harm the soil, but the operator is only allowed to use it 1000 hours per year due to radiation levels. This would not be a problem if the neutron backscattering method is mounted on a robotic platform.[27]

The rate of success with plastic mines of this method is around 96 %.[32] An overview of the advantages and disadvantages of neutron backscattering can be found in table 5.2.

	Advantages/disadvantages of the neutron backscattering method	
<b>Price</b>		Unknown
<b>Detection time</b>	Instant	
<b>Accessibility</b>		It may be hard to procure
<b>Accuracy</b>	Accurate	
<b>Versatility</b>	It detects hydrogen, which is found in the explosive substance inside the mine, and it therefore detects any kind of landmine and IED	

*Table 5.2 Advantages and disadvantages of neutron backscattering*

### 5.3 Biological methods

Biological methods have proven to be effective when searching for explosives. Two of the methods involve plants and African pouched rats. The African rats have a heightened sense of smell, allowing them to be trained to smell the different chemicals/explosives from the mines, much like a dog in an airport can sniff for drugs. The rat's sense of smell is so precise, that only 0.33 % of the time, they caught a smell from something else, making it a false positive. This means that when a landmine is found, more than 99 % of the time, they are sure to have found a mine. The rats themselves do not weigh a lot. They weigh around 1-2 kilograms and most of the mines require a pressure of about 5-6 kilograms. This allows the rats to move around in a minefield, without being in danger of triggering a mine. Manual labor is still required for this method though; the rats need to be trained first, which by itself could be costly both economically and timewise. Secondly, after a rat has found a mine, a deminer still has to go and dig up the landmine to neutralize it.[33]

Another biological method consists of using plants. The plants were biologically modified to change colour when they were in the presence of explosives. If the zone was free of mines, the plants would be green, otherwise they would turn red. The red pigment in the plant comes from the CHS (chalcone synthase) enzyme. This enzyme is related to the pigments in the

plant. It is unable to produce this enzyme unless it comes in contact with explosives. The plants would change colour within 3-5 weeks of growth.[34] An overview of advantages and disadvantages of the biological methods can be found in table 5.3.

	Advantages/disadvantages of the biological methods	
<b>Price</b>	Unknown	Unknown
<b>Detection time</b>		Takes long time
<b>Accessibility</b>	Unknown	Unknown
<b>Accuracy</b>	Highly accurate	
<b>Versatility</b>	Detects any kind of landmine and explosives	

*Table 5.3 advantages and disadvantages of the biological methods*

## 5.4 Nuclear Quadrupole Resonance

Another landmine detection method is to use the Nuclear Quadrupole Resonance. A NQR based device is able to determine the presence of nitrogen isotopes which are commonly found in explosives. This type of device is a proper tool to discover plastic made landmines. False positives caused by metal shrapnel or any other metal debris, which are common for metal detectors, can be avoided with this technology.

A problem with this solution is that low power pulses tend to generate interferences in the moment of reception. This may affect the precision of detection negatively. Background noise e.g. thermal agitation may cause difficulties in having a proper detection.

In 2003, this technology was tested by researchers from Quantum Magnetics in areas with desert and temperate climate during both night and day. The results had a 95 % rate of success in detection and only 5 % errors or false positives. These experiments were conducted on AT-landmines only.[35] An overview of the disadvantages and advantages can be found in table 5.4.

	Advantages/disadvantages of the nuclear quadrupole resonance detection method	
<b>Price</b>		Expensive
<b>Detection time</b>	Instant	
<b>Accessibility</b>		Low
<b>Accuracy</b>	High (AT-mines)	
<b>Versatility</b>		It only detects mines with a high quantity of explosive substance.

*Table 5.4 advantages and disadvantages of using nuclear quadrupole resonance*

## 5.5 Ground Penetrating Radar GPR

Ground penetrating radar(GPR) is an old method which was first used in the late 1920's. It was initially used to determine depth of a glacier, but later on the technology was used as detection of archaeological artifacts, landmines etc.

The technology locates objects under ground by emitting radio signals. One or more antennas emit radio signals, and the return signals is then collected by said antennas. A computer creates an image of the ground based on the collected data, with marks showing objects and their shapes and sizes. When emitting into plain soil, the feedback to the computer will be on a stable level. Objects hit by these emitted radio signals will change the signals going back to computer. The following process would be to analyse the signals and determine whether there is a landmine in the ground, based on the data received. Library indexes are used to compare the received signals with shapes and sizes of e.g. landmines, rocks or wooden sticks. Since GPR detection is based on an object's shape and size, it is possible to differ mines from other materials. Detecting IEDs will require a very large and specific library due to the varying shapes and sizes. Prevention of false positives will require an even more detailed library. A GPR system can be mounted onto vehicles due to its light weight.

Moist soil has proven to affect the outcome of data in a negative way because of a change in the returned signals compared to dry soil. Another disadvantage is that the operator has to choose between a good return signal or a good detection depth. Both cannot be attained because increasing the frequency of the signals will provide greater resolution but a poorer scanning depth.

Better processing of the data is still needed to make clear distinctions between landmines and natural clusters and thereby avoid false alarms.[36] An overview of the advantages and the disadvantages of using ground penetrating radars can be found in table 5.5

	Advantages/disadvantages of the ground penetrating radar detection method	
<b>Price</b>		Low
<b>Detection time</b>	Instant	
<b>Accessibility</b>	High	
<b>Accuracy</b>		Good (library dependent)
<b>Versatility</b>	High	

Table 5.5 advantages and disadvantages of using GPR



## 5.6 Summary and comparison of detection methods

*Based on the information highlighted in the advantages/disadvantages table, a comparison between all the methods mentioned in figure 5.6 will be made.*

Method\Key points	Time efficient	Inexpensive	Accuracy	Accessibility	Versatility
Metal detection	✓	✓	□	✓	□
Biological	□	✓	✓	Difficult	✓
Neutron backscatter	✓	□	✓	Difficult	✓
NQR	✓	□	✓	Difficult	□
GPR	✓	✓	✓(library dependent)	✓	✓

*Figure 5.6 comparison between the methods*

*This chapter described some of the current methods used for detecting mines. Some of these methods can be able to both detect metal mines and plastic mines, others only one of the two. The difference in time efficiency in the methods need to be taking into consideration when creating a robotic solution..*

## 6. Problem formulation

*How can a robotic solution use current technologies and methods to assist in demining processes around the world to reduce casualties and hindrance of development due to landmines and PPIEDs in current and post-conflict areas?*

## 7. Standards and guidelines

*The purpose of this section is to investigate whether there are standards and guidelines, that an ideal solution for humanitarian demining would benefit from following.*

The purpose of laws and standards for deminers is to ensure safety, efficiency and quality.

The IMAS (International Mine Action Standards) is a list of standards which are used for all UN mine action operations.[37]

The IMAS includes a big variety of standards to follow for humanitarian demining, many of which could influence the outcome of this project. A robot for clearing out mines, shall not harm the ground or destroy the intended purpose for clearance of the field. Therefore it shall be limited to erode the environment as little as possible, so the field is still suitable for the intended use. The robot will also need to be equipped with a fire suppression system, in case the robot catches on fire while operating in the mine field. This is to avoid the scenario of a person having to walk into a minefield in order to extinguish the fire.[38]

IMAS include some guidelines to follow when inventing new technology for humanitarian demining. The technology must be reliable, repairable, durable and maintainable. The durability and reparability is highly prioritized for mine action technologies. Ideally the robot will also have a broad utility, so it could be implemented in many countries. Then it could benefit from the economies of scale, which means that a higher quantity produced would lower the price per unit. It would also give a higher familiarity, availability and higher safety-feeling of the user. The robot will also need to have a certain technological maturity, which means it can not just be equipped with the latest invented mine detection technology, that have not yet been tested in a real life environment.[39] The draft board of these

guidelines include people from different high profile NGOs, i.e. UNICEF, ICRC and HALO etc.[39]. Since these are universal guidelines and requirements for humanitarian demining, following these would potentially increase the chance of them supporting the robotic solution.

*The standards listed in IMAS are followed and supported by several big mine action NGOs. By following these standards, the final solution in this report will better the chances of getting support from mine action programs.*

## 8. Requirements and delimitations for ideal solution

*This chapter will present delimitations for the project based on the knowledge obtained in the problem analysis. Furthermore, a collection of the requirements for the ideal robotic solution will be listed.*

The problem analysis showed that the largest percentage of casualties is civilians. In addition, military demining operations often require disposal immediately which current solutions already perform well. Therefore, humanitarian demining will be the focus for this project.

The final solution will be able to optimize the rate of demining and increase the safety for the civilians, and also for the deminers performing the dangerous task that it currently is.

Research on the different kinds of landmines and IEDs made clear that the differences in types of especially IEDs are big. This project narrows down the targeted explosives for detection to landmines and PPIEDs planted in the ground. The reason for choosing these two explosives devices is that they have many similarities; they are both causing a large negative impact on civilians, both regarding casualties and economically disbenefits.

Requirements for an ideal solution will now be presented in order to make some guidelines for the upcoming solution proposals.

**High speed:** Faster detection rate would optimize the process demining

**Operate autonomously for long periods of time:** The ideal robotic solution will be able to operate until all landmines and PPIEDs in the desired operating field are detected. Required

stops and breaks, e.g. for charging, will slow down the demining process and the robotic solution will be less of an advantage for the deminers.

**Obtain safe operating distance:** There will be a safe operating distance for the deminers so that no humans have to enter the area of operation in order to detect landmines and PPIEDs in the ground. The ideal solution will be able to manually shut down or be remote controlled in emergency situations.

**Operate in different terrains and weather conditions:** In order to be versatile, the ideal robotic solution will have no constraints regarding operation in different terrains and weather.

**Detect all types of landmines and PPIEDs in the ground:** Detecting all different types of landmines and PPIEDs in the ground is important in order to perform the desired operation properly. If the robotic solution cannot detect all types of mines, the demining process would require different methods to aid in the detection process. This would be an unnecessary and very costly process.

**Low rate of false detections:** The ideal solution would have false detections in order to be as effective, safe and durable as possible.

**Clearly mark found explosives:** Detected explosives will be clearly marked on a map in order to optimize the process of landmine disposal. The robot will create a map with the markers to show where there are explosives.

**Low price:** Price is an important factor to look at when creating a robotic solution, especially when it is used for humanitarian demining. The ideal solution will be cheaper than similar solutions with same qualifications.

**Durability:** The ideal solution will be durable to the point where it is almost indestructible against landmines and PPIEDs. In situations where an explosive by mistake goes off, it will be able to withstand the blast.

*This chapter presented different requirements for an ideal solution based on the delimitations also presented in the chapter.*

## 9. Solution proposals

*Four different solutions are proposed in order to decide on the final product. For each of the ideas, an analysis will be presented to give an insight into the pros, cons and design of the robot. Lastly, a final solution will be presented based on the analysis of the proposals.*

### 9.1 Proposal 1 – Heavyweight

The first idea is a big and heavy vehicle. It will be strong enough to withstand the explosion of a landmine and also big enough to have a compartment where it can dispose the landmines. The core idea behind it is to make demining completely autonomous, but unfortunately that comes with a high cost. The robot will detect the mines and afterwards dig up the mines. This will make sure that the deminers are not interacting with the landmines. For movement, track wheels will be implemented to make sure it is capable of driving in a big variety of terrains.

#### 9.1.1 Speed

The robot is capable of going at a relatively high speed when driving, but is hindered by its method of disposal. However, it will need to make some stops along the way to dig up the landmines and PPIEDs found. This robot will be the fastest, out of all the proposals, at demining. In the forthcoming solution proposals, a deminer would still need to dispose the mine, whereas this robotic idea would dispose it itself.

#### 9.1.2 Autonomous availability

This robot will primarily be autonomous. If it is needed, the robot is able to be driven by a human. The only action that would require human interaction, would be to initialize the robot's operation and for transportation.

### 9.1.3 Mobility and durability

The robot will be very durable since the material, which it will be made of, is able to withstand an explosion. The track wheels will enable it to maneuver in a wide array of terrain, allowing a high mobility. A sketch of the robot is shown in figure 9.1.

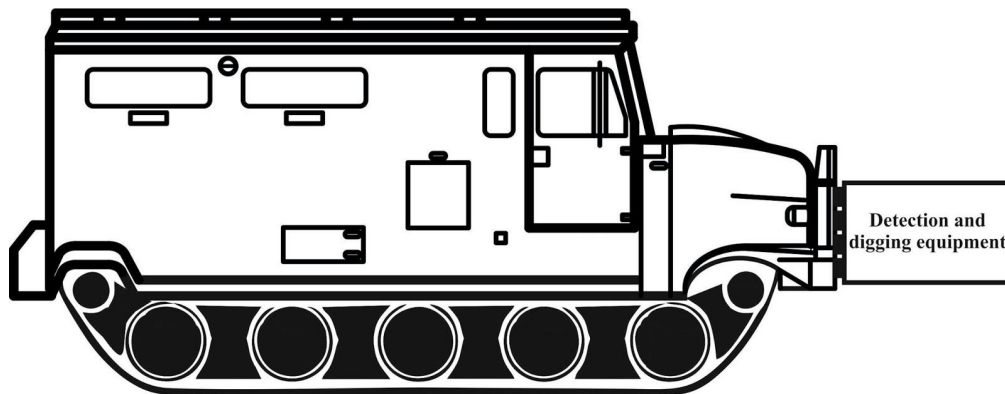

*Figure 9.1 the basic concept of solution proposal 1.*

### 9.1.4 Detection

For detection, the robot in question will use neutron backscattering to locate the landmines and PPIEDs. If needed, metal detectors could also be applied to it. The robot will detect the explosives and afterwards dispose them, whereas the other proposed robots would only detect and then make a map of the explosives

### 9.1.5 Price

The robot would be very expensive and highest likely the most expensive of all the proposed solutions. The materials strong enough to withstand explosions would require expensive resources. The system that makes the robot able to detect and dispose the mines would also be very costly.

### 9.1.6 Conclusion

This idea is very expensive but also the one capable of performing the whole operation all by itself. The high durability and mobility will allow it to operate in almost any terrain and can also withstand explosions of landmines.

## 9.2 Proposal 2 - cheap and lightweight

This solution is a small sized robot based on the platform of the Kobuki Turtlebot (see picture 9.2) with a 355mm diameter and 420mm height, weighing 6.5 kilograms. It is designed to be agile and portable, and it is suitable for flat terrains without a lot of vegetation. It is moving on three small wheels, two for actual movement and one for stabilisation. The material is cheap and lightweight; plastic and aluminium. This makes the robot accessible for private users like farmers who want to ensure the safety of a plantation contaminated with landmines and PPIEDs. The robot will provide detection and mapping in an autonomous way, which means that it will locate and tag the location of the detected landmines and PPIEDs with specific coordinates for them to be handled later. The robot will be equipped with metal detectors that are mounted around the front section of the robot. The other sensors are related to movement, mapping and localization. The power consumption is quite low with a battery operating time of around twelve hours. The battery may be charged during the day using solar panels, mounted on the top of the robot, or at the docking station.

### 9.2.1 Speed

Due to the small size, the robot might be able to reach a high maximum speed without consuming a large amount of energy in the process. When it comes to clearing mines at a fast rate, it might not be very effective as it needs to perform many turns in order to cover the same area as a bigger robot e.g. solution proposal 1.

### 9.2.2 Mobility and durability

This solution will be able to run for a long period of time, due to its low energy consumption. The robot will consist of small wheels, meaning that it will not be able to cover rocky areas. If it encounters an area with tall grass, the sensors will not be able to work properly because the grass can be taller than the robot. The weather resistance of the robot depends on the type

of plastic the robot is made of. Some plastics are more durable than others, e.g. under exposure of high temperatures where some cheap plastic parts might decompose. In addition, the low weight of the robot might cause it to be damaged or tipped on the side under windy circumstances.

### 9.2.3 Detection

This robot is capable of detecting all types of metal landmines and PPIEDs. It is using a metal detector, which can give a lot of false positives when it finds a decent sized piece of metal in the ground. The robot will not be able to detect mines which does not contain metal. The robot will not be able to ensure that no landmines or PPIEDs are left on the possible minefield.

### 9.2.4 Price

The price of the robot will be relatively cheap compared to the other solution proposals. The materials which it is made of are cheap and it is small compared to the others.

### 9.2.5 Conclusion

The robot is intended to be purchased by private users who may not have a lot of money, therefore the materials of which it is made are required to be cheap. Since the cheap price is a high priority, it takes its toll on the quality of the robot.

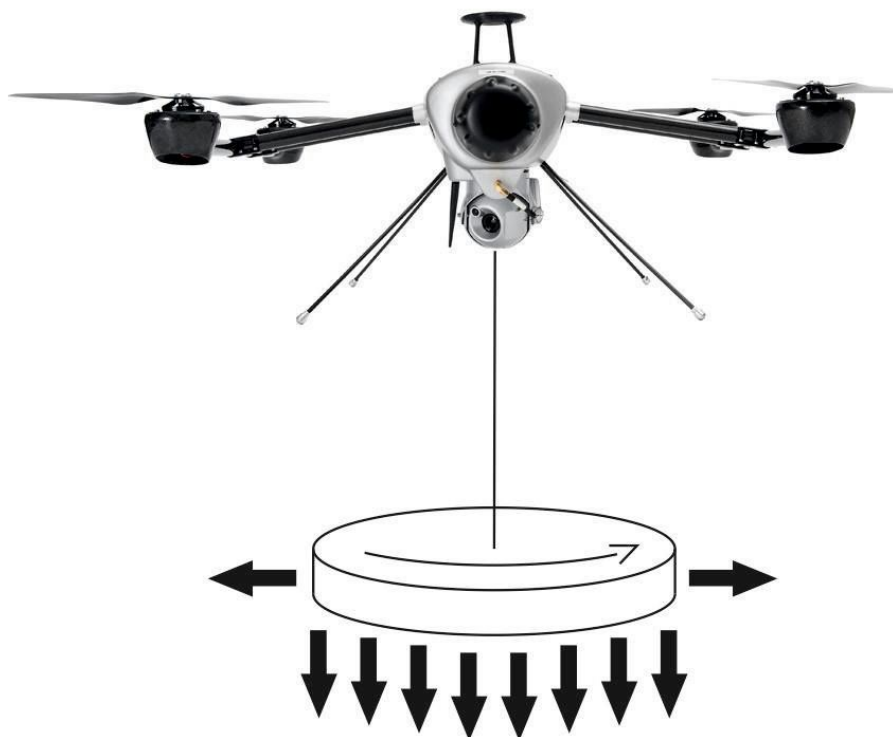

*Figure 9.2 the basic concept of solution proposal 2.*



### 9.3 Proposal 3 - Drone

The robot in question would consist of an average sized drone capable of carrying a bag of seeds. Said seeds would be the ones mentioned in section 5.3. The seeds have been gene modified to change color when they come in contact with explosives. Its purpose would be to spread out the seeds in a designated field or area. A stock of seeds, either in a bag or container, would be attached to the drone. The part of the drone carrying the seeds, would be spinning around, so the seeds would be flung out to cover a larger area than the designated flying path will cover. A basic representation of the robot is seen in figure 9.3. The drone will fly over the designated area and cover it with the seeds. After 3-5 weeks, the seeds will either be colored green or red, determined by if there is explosives in the ground or not. The drone would scan the entire area from above and essentially create a map of landmines and PPIEDs, after the plants have grown.



*Figure 9.3 the basic concept of solution proposal 3.*

### 9.3.1 Speed

The speed of the robot would be dependant on several factors. First of all, the process of spreading seeds will be executed within a short time span in order to keep the growth of the plants concerted. A fast spread of the seeds will give the most useful result(see section 9.3.4). However, the speed of the robot will not be on the expense of proper spreading of the seeds. A velocity that is too high will result in a bad and incomplete spread, which will naturally affect the end result of the detection method.

### 9.3.2 Autonomous availability

Even though this is an excellent and consistent method for detecting explosives in the ground, the plants cannot in any way dispose the mines. Another potential problem with this solution is the energy consumption and limited battery size. An airborne drone uses a lot of energy to function(compared to a grounded solution), and a typical drone can function for around 15-20 minutes before recharging the battery or replacing it with a fully charged one. Bigger batteries are heavier and therefore not optimal to carry; extra weight means higher energy consumption. The extra weight added from carrying the seeds(around 50 kilograms of seeds per 10 km<sup>2</sup>) will increase the energy consumption. This makes this solution fairly limited, both in terms of range and efficiency, with a carry capacity of 10 kilograms which results in a range of approximately 2 km<sup>2</sup>.<sup>[40]</sup>

### 9.3.3 Mobility and durability

The robot is more or less only able to operate in large open areas, such as plain fields, bare soil and mountains. If it operates in e.g. a forest, it might have some problems due to the seeds not being able to grow because of the other plants, but also because the drone will have to navigate around the different obstacles, such as trees and branches, which could make it less accurate when planting seeds. Windy weather will also cause some problems for both the spreading of the seeds and the maneuvering of the robot. Wind might push the robot out of its desired path and hence spread the seeds in a less accurate way. In the same sense, wind might also cause the seeds to land in a completely different area than what would be expected, meaning that it would not cover the area in a precise manner, which could cause an explosive to go unnoticed. The weather will have to be calm for the robot to operate. On the same note,

after the seeds have been spread across the field, they will still require a certain amount of water to grow. If the soil is too dry, the seeds will not be able to grow and if it is too wet, the seeds will drown. There will be a need of either rain or water to be sprayed on the field if the field is not humid enough as it is.

#### 9.3.4 Detection

The method of detection is a biological process. As previously stated: After the seeds have been spread out, it will take 3-5 weeks for them to grow and develop their color. After the plants have grown, the robot will then be sent back to the area, to do an aerial scan of the area and then make a top-down map of the area, giving an overview. This map will have two different colors which determines the result of the detection. In reality, plants that are in contact with explosives will have a different color than those which are not. This will ease the following disposal of the explosives.

One thing to keep in mind is the probability of both false-positives and false-negatives. False-positives could be a scenario where a plant is in contact with some material that contains the same chemical compounds as explosives. The plant will in that case display as the green color. A false-negative would be the opposite where the explosives are not detected, either because the plant cannot detect the explosive material within the device, or because the spreading of seeds failed to cover all areas within the field.

#### 9.3.5 Price

The price of an average drone is 6000-9000 DKK [40]. The drone would need to be able to lift a bag with enough seeds to cover a large area. This means that the drone in question would require more buoyancy than an average drone. A modification like this would require that the drone has more power, which will increase the energy consumption. This requires a larger battery, adding more weight to the robot and raising the price.[40] The cost of the seeds must also be taken into consideration.

### 9.3.6 Conclusion

The idea itself could possibly be implemented, but due to its lack of mobility in different weather conditions and environments, it is not an applicable solution. It has an overall good efficiency in covering an area with seeds, but the time it takes for the seeds to grow, if they even grow at all, will take too long for the method to be directly efficient. In addition, this solution will require a steady supply of the seeds in order to carry out its function. Humans will still have to get up close with the mines and explosives since the drone cannot remove the mines, only detect and map them.

## 9.4 Proposal 4 - Hovercraft

A hovercraft works by blowing air into a cushion under the hull of the vehicle retained by the skirt, thereby creating a pressure that lifts the hull off the ground. This process is illustrated in figure 9.4. In this picture propellers(1) provide thrust to the hovercraft, while a stream of air(2) is distributed, by fans,(3) into the air-cushion retained by the skirt (4). A continuous airflow keeps the vehicle hovering while the air escaping from underneath the skirt keeps the vehicle balanced.[41] The weight of the hovercraft is supported by the entire surface area of the air-cushion. Because of this, the pressure on the ground, generated by a hovercraft, is much lower than the pressure generated by a wheeled or tracked vehicle. In specific, the pressure is around 383-479 pascals which is equivalent to 39-49 kg/m<sup>2</sup>. [42]

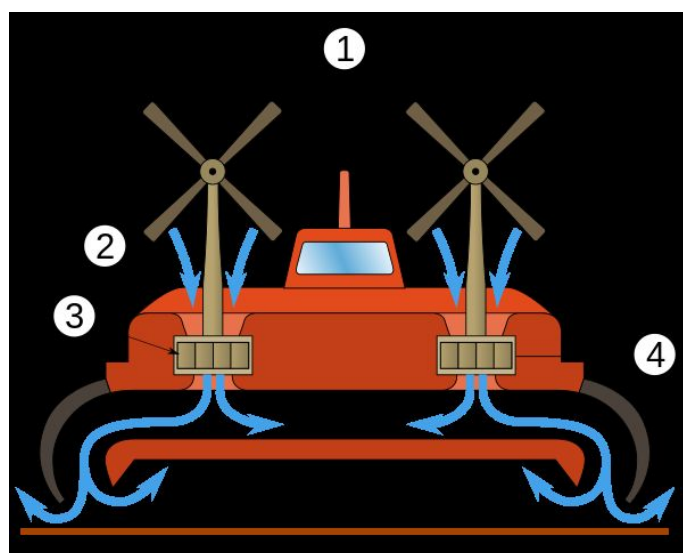

Figure 9.4 Hovercraft illustration [43]

Once the vehicle is lifted by the air-cushion, forward thrust must be created. This is done in one of two ways. The first and most common way of creating forward thrust is to have a separate motor dedicated to this function, but it is also possible to have a motor that provides both lift and thrust. An example of a hovercraft with this system, referred to as an integrated system, is seen in figure 9.5. From this figure it is possible to see that part of the air-stream generated by the fan is transferred into the skirt to create the air-cushion while most of the air stream is still used to create a forward thrust. An integrated system cannot provide lift without also providing thrust. Therefore, a hovercraft with an integrated system is not able to hover at a stationary location.[44]

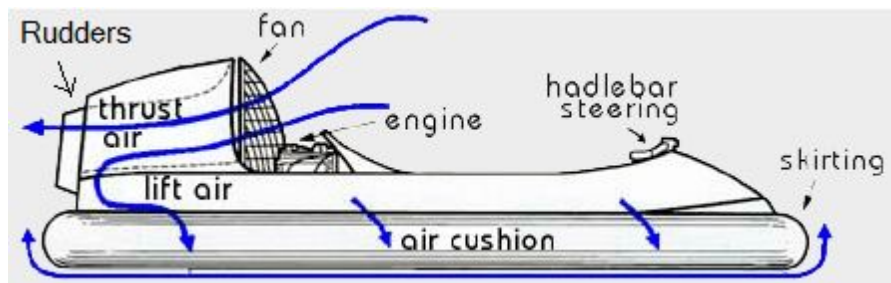

Figure 9.5 Hovercraft with one motor used for lift as well as forward thrust.[45]

Another detail in figure 9.5, which makes it stand out from figure 9.4, is the indication of a steering handlebar. The handlebar controls the rudders, placed behind the fan, which serve the purpose of controlling the direction of the vehicle. In that way, the control of a hovercraft is similar to that of an aircraft.[46]

The skirt is an important and characteristic part of a hovercraft. While skirt design can vary a lot, there are three commonly used types of skirts namely the bag skirt, the segmented skirt and the juped skirt.

The bag skirt consists of an air-cushion tube surrounding the perimeter of the hull. The segmented skirt is also known as a “finger” skirt. The skirt surrounds the perimeter of the hull just as the bag skirt. However, where the bag skirt is one big tube, the segmented skirt consists of several individual segments looking a bit like fingers on a clenched fist. When inflated, these segments are pressed together and make up the air-cushion. The segmented

skirt is more complex than the bag skirt, but it does also provide several advantages. For example, it has a better ability to pass obstacles compared to the bag skirt and it gives the option to replace certain, possibly damaged, segments of the skirt making it easier to repair. In exchange for this convenience the segmented skirt is not as stable as the bag skirt. Finally, the jupe skirt has cells, looking like cones with the top cut off, attached with their bases to the bottom of the vehicle. Generally, there is at least 2-3 cells attached to the bottom which are encircled by a jupe that also surrounds the perimeter of the vehicle. One of the big advantages of the jupe skirt is the excellent stability that it provides.[44]

Material used for the hull and the chassis of the hovercraft also varies a lot. Common materials include aluminium, plastic, fiberglass and plywood. An alternative to using one of these materials is to use a sandwich-structured composite in order to make a hull with high strength while retaining light weight. A sandwich composite is obtained by attaching two skins to a core with an adhesive. Optimally, the skin must be thin, strong and stiff and the core needs to be thick and structurally strong but also lightweight.[47] Figure 9.6 shows the structure of a sandwich composite.



Figure 9.6 Structure of a sandwich composite [47]

#### 9.4.1 Speed

The hovercraft robot will be able to detect mines fast. It will not apply much pressure to the ground when it is operating. As long as the mines are triggered by pressure, it will not have to go around them when they are detected. Instead it can just go right over the mines without triggering them. This limits the amount of turns the robot has to make and allows it to keep a constant speed for longer periods of time. Since the friction between the ground and the hull of the robot is non-existent due to the air-cushion, this robot will be capable of moving at a high speed. While the average speed of a hovercraft is around 56 km/h, depending on terrain and weather, some hovercrafts move at speeds over 110 km/h. hovercrafts are fastest on smooth and flat areas.[46] Because of this, it will most likely be the sensors applied to the

robot that limit the operating speed, rather than the robot itself. The chosen size of the hovercraft will affect the detection speed. A large hovercraft has the possibility to detect an open area faster than a small hovercraft. However, the smaller hovercraft will be more viable in narrow spaces.

#### 9.4.2 Autonomous availability

The goal is to make the vehicle operate autonomously hereby negating the need of an operator.[44]

The proposed solution is not equipped with a mechanism to dispose the mines, so landmine disposal maneuvers has to be made by deminers in case of a positive detection.

Operating time will depend on the chosen energy source. It is very common for hovercrafts to be powered by diesel or gasoline engines, which gives them a decent operating time and range.[41] As an example, the *Renegade IQ Hovercraft* has a range of 241 km and an estimated operating time of 4.5 hours.[42] Battery powered hovercrafts exist, however, they do not have as good of a range and operating time as the ones powered by diesel or gasoline engines.[48]

#### 9.4.3 Mobility and durability

The hovercraft will be able to operate efficiently in many terrains and weather conditions. It functions on e.g. mudflats, fields, sand and swamps. Therefore, operating in parts of countries like Afghanistan and Pakistan, which are among the countries heavily affected by mines and ERW, will not be a problem. Due to the flexible skirt of an hovercraft it is also able to clear obstacles.[41] The size of the obstacles it is able to clear depends on the hover height of the vehicle. They cannot be too big, as the height can decrease the stability of the hovercraft. If the hover height is too tall, the hull will slide off the cushion.[46] Covering bare soil or grass fields will not be a problem, given that there are no big obstacles such as big rocks or bushes. To work in areas with such large obstacles, the robot must have a function capable of avoiding them.

Durability of the vehicle depends on the choice of materials and components such as skirt type and material for the hull. The most durable skirt type is the bag skirt. However this type

is not easy to repair and the obstacle clearance is poor. Therefore, the durability of the bag skirt does not come without drawbacks and is not the most suitable skirt type when it comes to autonomous landmine detection. Regarding material for the hull, a sandwich composite is a viable choice. As an example, the *Renegade IQ hovercraft* uses a sandwich-structured composite consisting of a foam called divynycell as the core and kevlar as the skin.[42] Sandwich composites give a very good strength to weight ratio along with many other benefits (see section 9.5).[47]

#### 9.4.4 Detection

The hovercraft will have a GPR system for detection. Antennas will be attached on top of vehicle pointed towards the ground. The GPR system will emit radio signals into the ground and receive the returned radio signals. The computer will create an image of the soil beneath the vehicle, it will then combine all the collected data into a map of the d area. The idea behind the hovercraft is to move around the area of detection without applying pressure to the ground and therefore not triggering the specific explosives it will detect. After the detection of the desired area is complete, a map of the area is created and landmine disposal maneuvers can begin. This solution will not trigger the explosives in the case where the sensors fail to detect it because of the low pressure that is applied to the ground.

#### 9.4.5 Price

The company Neoteric Hovercraft Inc, produces hovercrafts for human transport. These vehicles cost from 16000 USD up to 65000 USD.[49] A potentially smaller vehicle not meant to carry much weight might be cheaper. Small remote controlled hovercrafts, can be bought for the price of 250 USD[50]. The price for the base will depend on the chosen size of the hovercraft. The sensors that need to be attached to the hovercraft will also add up the the total price. The computers mounted will increase the cost of the product. The ground penetrating radars vary in price based on frequency and size. Figure 9.7 shows a model of the proposed solution.



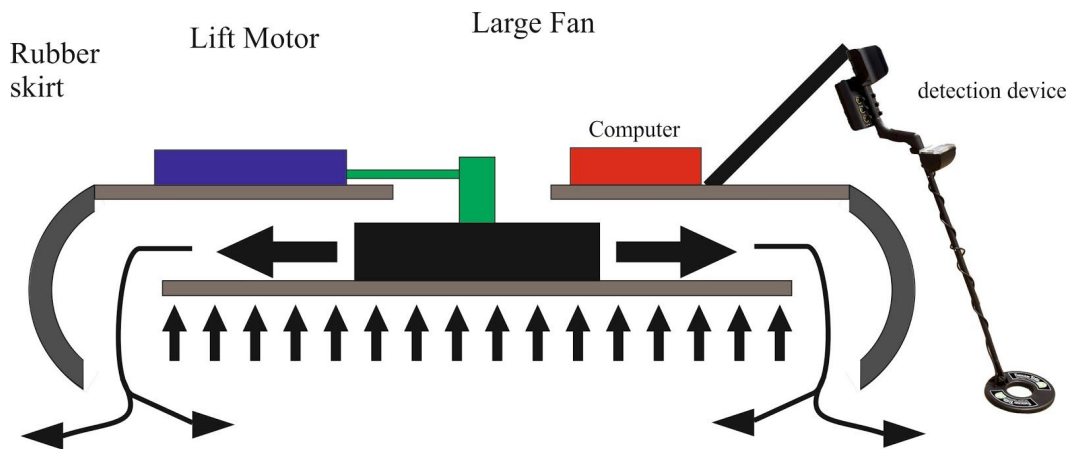

Figure 9.7 Illustration of the proposed idea

#### 9.4.6 Conclusion

There are big advantages of using a hovercraft as the the movement base in landmine detecting operations. It is fast, mobile and reasonably durable. Most importantly it does not apply enough pressure to the ground to trigger mines. This makes the process of mapping a minefield much easier and reduces the risk of the robot being accidently destroyed by mines. On the other hand it cannot guarantee that all mines have been detected. The use of a ground penetrating radar for detection is a viable possibility, but will require a big library of shapes and sizes to function properly.

#### 9.5 The final solution

Based on the 4 solution proposals in the previous chapter, a final solution will be presented in this subchapter. Taking the best aspects of each of the proposals, a final robotic solution is built with the concept and hardware chosen to give the best presentation of the desired product. The concept of our idea is illustrated in figure 9.8.

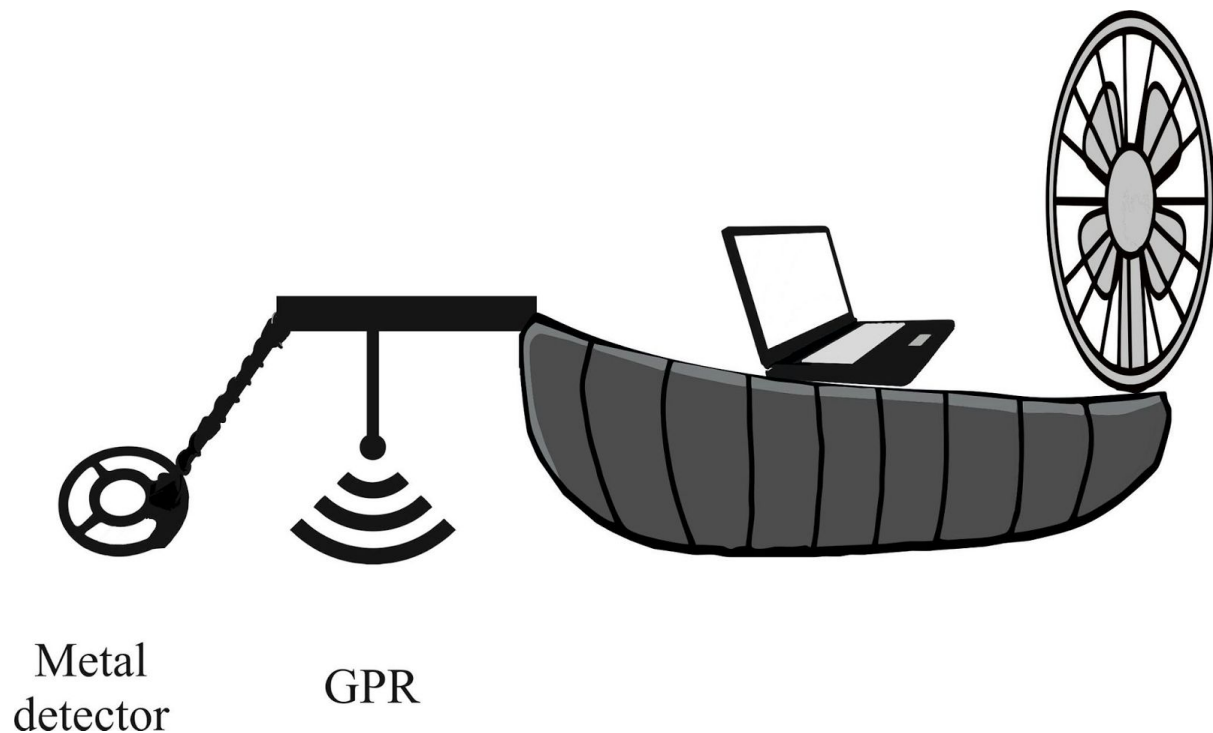

Figure 9.8 illustration of the final solution

### 9.5.1 Hovercraft pillow for movement

A potential base model for the robot would be the *Renegade IQ hovercraft* from the company Renegade Hovercraft.[42] The IQ is capable of carrying 2 human passengers, which may not be necessary for the robotic solution.

The point of using this hovercraft as an example is to show that hovercrafts are applicable for the final solution and that there are advantages of using a hovercraft in landmine detection operations. The hovercraft is capable of having a payload of 209 kg, which is more than enough to carry equipment needed for navigating, mapping and detection. In regards to speed, the IQ hovercraft is capable of going up to 76 km/h. The hovercrafts size and speed will be optimized to benefit the robot in a proper manner. This hovercraft could be downsized a lot as the robot will be autonomous and would not require space for anything but technical equipment. The standard IQ hovercraft is able to drive 241 km on a full tank, making it capable of covering a rather large area before having to refuel. The Renegade IQ hovercraft is equipped with a segmented skirt. Figure 9.3 compares the segment skirt to the bag- and jupe skirt in order to highlight the benefits of using the segment skirt type in landmine detecting operations.

**Comparison between skirt types [51]**

	<b>Bag</b>	<b>Segment</b>	<b>Jupe</b>
Cost	Low	High	Low
Durability	Good	Poor	Moderate
Repairability	Hard	Easy	Hard
Stability	Good	Poor	Excellent
Obstacle clearance	Poor	Good	Poor
Performance when damaged	Moderate	Good	Poor
Bounce	Poor	Good	Good
Ease of attachment	Moderate	Easy	Moderate hard
Drag: Grass	High	Low	Medium high

*Figure 9.3 Comparison between the three common skirt types.*

As seen in figure 9.3 the segment skirt is easy to attach and easy to repair. The drag is low on many surfaces including grass, which contributes to high fuel efficiency. A good obstacle clearance capability provides good mobility and with a manageable bounce the technical equipment is spared during operations. The segment skirt has poor stability compared to the other skirt types, which has to be counterbalanced in order to make the vehicle operate autonomously. Another disadvantage of this skirt type is the poor durability. It is compensated for, by the skirt's ability to function well when damaged and the fact that it is easily repairable.

Asides from the skirt, the Renegade IQ hovercraft is made of durable components and materials. As previously mentioned, the hull of this hovercraft consists of a sandwich-structured composite with divinycell foam as core and Kevlar as skin. In addition

to the strength/weight ratio, there are several advantages of this construction. It is resistant to corrosion and does not require much maintenance. The composite structure of the hull also works well with the detection units on the hovercraft. Because there is no metal in the hull, it is nonmagnetic, which improves the use of sensitive electronic equipment, such as a metal detector, to be implemented on the hovercraft. Furthermore, the composite structure is radar transparent; radar signals can go right through the structure allowing effective use of radar equipment such as the GPR. The composite structured hull is also sustainable in the way that only a small amount of raw materials are used to create it. The lightweight construction of it also improves fuel efficiency and thereby reducing emissions. Finally, the divinycell foam has excellent fire, smoke and toxicity attributes. In fact, divinycell HT foam, which is ideal for structural design in light aircrafts among other things, has the ability to self-extinguish in case of a fire.[47] The attributes of the hovercraft, as well as the detection technologies implemented on the hovercraft, all apply to the standards listed in the IMAS.

The cost of the Renegade IQ is 32.000 \$, but this price is only for reference. The final price will be different due to various modifications.

### 9.5.2 Metal detector and ground penetrating radar

To detect all kind of landmines and PPIEDs, the robot will use both a metal detector and ground penetrating radar as the sensors. This allows for high accuracy when searching for landmines and PPIEDs. The combination of the two will allow for a better detection. For the metal detector the military-grade F3 landmine detector by a company called The Minelab could be attached to the robot.[27] The F3's technology is accurate and has a port for datalogging, allowing it to potentially be applied to a robot. The data from the sensors will be sent to the processing unit of the robot, and a mark will be set on the created map to indicate the location of the mine. The coil of the metal detector has a size of 200mm which is the standard size. This size could be adjusted to fit the robot in a better way.

### 9.5.3 Processing unit

The processing unit for the robot will be a computer. The computer will process the data received from the sensors and create a map with marks highlighting the places with positive detections. The computer could either be stationary on the robot or a computer with a

wireless connection to the robot itself. The wireless connection would allow the user to view the map and make modifications from a distance e.g. draw a route through the minefield for the demining operations. Alternatively, the processing unit could be incorporated with the robot itself and then deliver the gathered data, once the processing is done. The only requirement for the processing unit is power, it has to be strong enough to analyse and receive the data from the sensors.

*After presenting four different solutions with each their unique traits, a final solution has been created with inspiration from the others. The final solution will be a hovercraft that is able to detect mines by using GPR and metal detectors.*

## 10. Prototype

*In order to demonstrate the final solution for an autonomous mine detection robot, a prototype will be developed as a simulation of the final product. This prototype will operate in a fixed environment using replacements for real mines and obstacles. It is important to mention that the basic principles of the prototype apply to the final solution for a mine detection robot.*

### 10.1 Hardware components

This section covers the hardware components of the prototype solution. All the components are included in the Turtlebot 2 complete kit.

#### 10.1.1 Kobuki base

The Turtlebot 2 has a cylinder-shaped body called the Kobuki base. It has a diameter of 35,5 cm and is equipped with support racks, for placement of a notebook computer, sensors, cameras etc. The height of the base(including the racks) is 42,0 cm. The height of the base unit itself is 8,9 cm. The Turtlebot 2 weighs 6.5 kg, has a maximum payload of 5 kg and a top speed of 0,65 m/s(approximately 2,34 km/h). In figure 10.1, the Kobuki base is illustrated.[52]

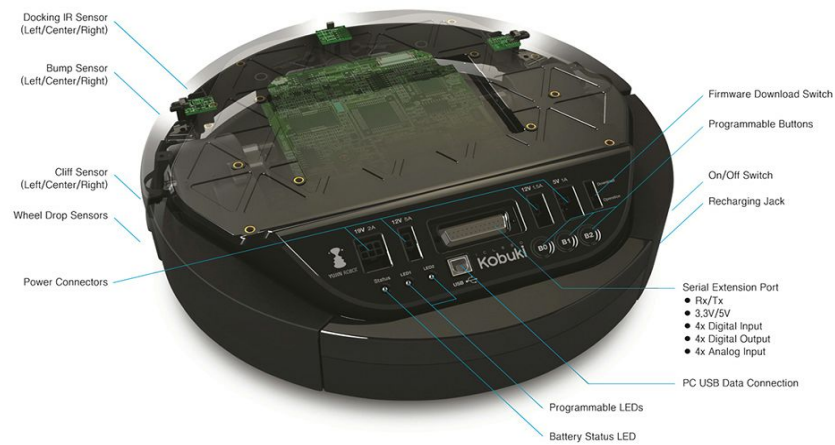

10.1 Turtlebot Kobuki base [53]

### 10.1.2 Asus Xtion PRO LIVE

The turtlebot is mounted with an Asus Xtion Pro LIVE (figure 10.2) sensor station, which combines different sensing methods. The unit combines RGB sensing (a method that creates a representation of images as a combination of the colors Red, Green and Blue) with infrared sensors and depth detection technology to define the surroundings of the turtlebot. It also has the ability to detect audio signals.



Figure 10.2 Asus Xtion PRO Live [54]

### 10.1.3 Asus X200M Notebook

The notebook is used as an operation unit for the turtlebot. It is running on Ubuntu 14.04 and uses ROS (Robot Operating System) in order to interact and execute the software provided for the turtlebot.

The specifications of the notebook is listed below:

- Intel Celeron N2830 dual core, 2.16GHz
- 2.0 GB RAM
- 500GB HDD

For more complicated projects and more advanced systems, a stronger computer would be required. However, for this project a computer with these specs are capable of executing the programs and process the necessary data from the hardware.

### 10.1.4 Sensors

There are three types of sensors on the prototype

#### **Cliff/IR sensors**

The cliff sensors on the turtlebot are IR(infrared) sensors that emit and receive IR signals. The sensors are placed at the bottom side of the Kobuki base; one right, one left, one center. IR signals emitted by the diodes of the sensors will return after hitting the surface right below the sensor receptors, and the time between emission and reception of the signal will indicate the distance between the sensor and the surface right below it. This method is commonly used for detecting and avoiding bad paths,hence the name (the sensors can avoid “cliffs”, stairs etc.), and can also be used to detect obstacles.

#### **Magnetic field/Orientation sensors**

The magnetic field sensor, also known as the orientation sensor, utilizes the occurrence of a change of path for the electrical current between a conductive object that is fed with electricity and a magnet. The electrical charges moving through the object will create a magnetic field of its own. This field will interfere with the magnetic field of the magnet and

force the current change in path through the object. The sensor will detect this change of path, or rather the direction of the path, and then determine the position of the sensors.[55]

### **Rotary encoder**

The rotary encoder estimates the distance traveled by measuring the rotation of the axles. Estimating the distance traveled will also make it easier to calculate the speed and odometry of the robot.[56]

#### 10.1.5 Price

The retail price of the Turtlebot 2, as well as some of the major and commercial components, are listed below. Beware that the prices may vary.

- Asus Xtion PRO LIVE: 169,00\$(1150 DKK).[57]
- Asus X200MA Netbook(newer model): 339,00\$(2330 DKK).[58]
- Kobuki base: 547,33\$(3723 DKK).[59]
- Turtlebot 2 complete kit(with Xtion and notebook): 1.425,76\$(9700 DKK).[59]

## 10.2 Concept and operating modes

The following subchapter will provide a description on how the turtlebot prototype will demonstrate the idea for the final solution described in section 9.5.

### 10.2.1 Detection

The method used to detect the mines is based on the depth sensors of the turtlebot. The sensors are constantly measuring the distance from the Kobuki base to the ground. If the deviation from the initial value reaches the predetermined value for detection ( $\Delta x$ ) (*Figure 10.3*), a mechanism is triggered, making the robot stop and register the object of interest – in this case the mine. The initial value is determined by the distance from the robot's base to the ground, from the moment the encoders node is initialized.



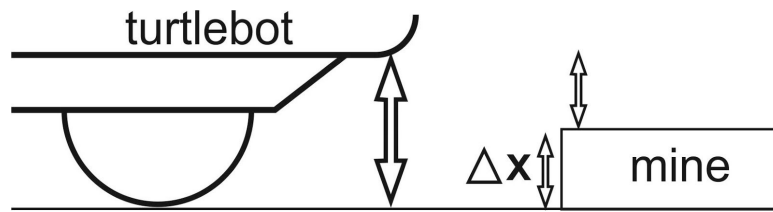

Figure 10.3: Detection method

## 10.2.2 Movement

The robot uses an algorithm to carry out the movement which will scan the designated area systematically. The user can input 3 variables, the dimensions of the field (length and width) and which side of the area that the robot is on. The side is a significant input, as it will guide the robot which way to turn after reaching the input length, and also which way to go around the mine in case of an encounter.

In the optimal case, the path of the robot is going straight for the entire length of the input field, turn 90°, go forward 35 cm turn 90° again, and continue until the entire field is scanned (Figure 10.4). 35 cm is used as the base in navigation, since it is the diameter of the base of the turtlebot.

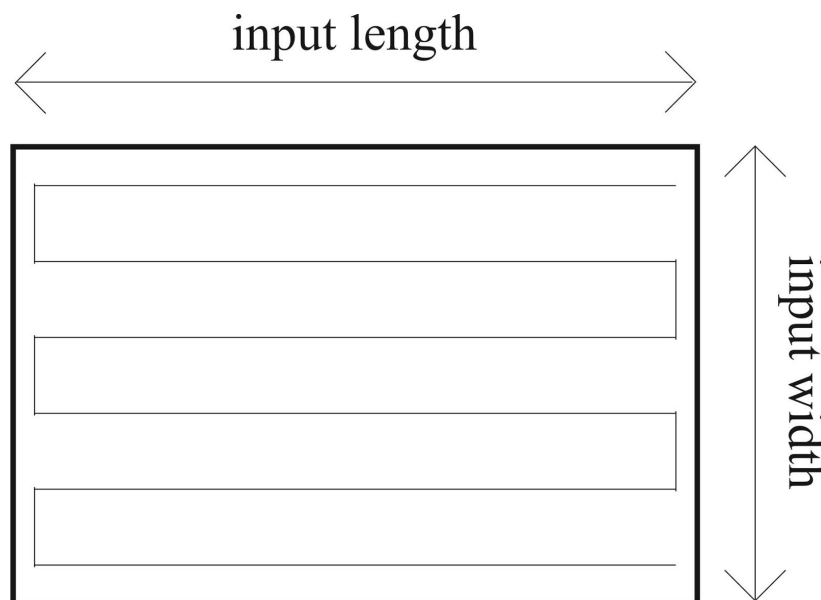

Figure 10.4: Default movement pattern

In case of a encountering a mine the robot will maneuver around the mine and return to its original path. The procedure will be carried out (as shown in Figure 10.5) with the robot stopping, turning 90° (1), going forward 35 cm (2), turning 90° again in the opposite

direction (3) and going forward  $2 \times 35$  cm (4), then turning  $90^\circ$  (5), going forward 35 cm (6), and turning  $90^\circ$  in the opposite direction (7).

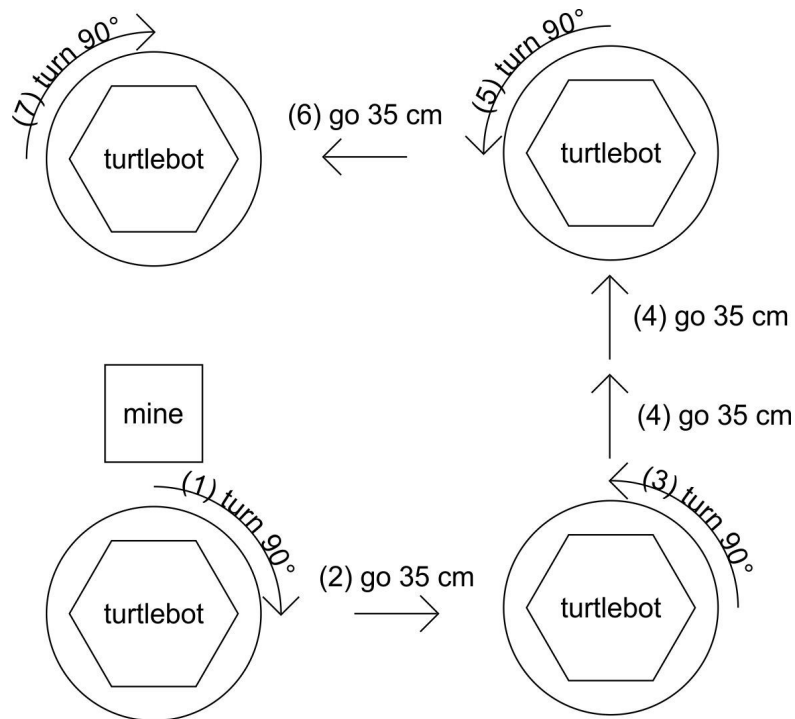

Figure 10.5: Sequence of movement in an encounter with a mine

## 10.3 Software

A main component of the proposed prototype is the software. The main purpose of the software is to centralize and control all the components which are available through hardware configuration and customization. There is no possibility for hardware to work without software and there is no sense for software without hardware.

### 10.3.1 ROS

ROS (Robot Operating System) is the operating system software of the mine detector prototype implemented on the Kobuki Turtlebot platform. ROS makes low-level control and complex operation of multiple sensors and motors possible which is needed to demonstrate the final solution.[60]

One feature which is important for the software component is that multiple programs (also known as nodes) can be executed at the same time.[60] The significant detail of ROS

programs is that they can communicate between each other using a publisher-subscriber pattern.[61]

Nodes are publishing data on a specific topic to which other nodes may subscribe in order to receive the data. The nodes are not directly dependent on each other, which means that the subscriber does not need to be aware of details about the publisher and vice versa. This means that a program which executes code written in e.g. Python is able to communicate without problems with a program which executes code written in C++.[61]

In *Figure 10.6*, the connection between hardware and different software components is illustrated. The figure shows that ROS makes the low-level control of the hardware components possible while the nodes are controlling these interactions.

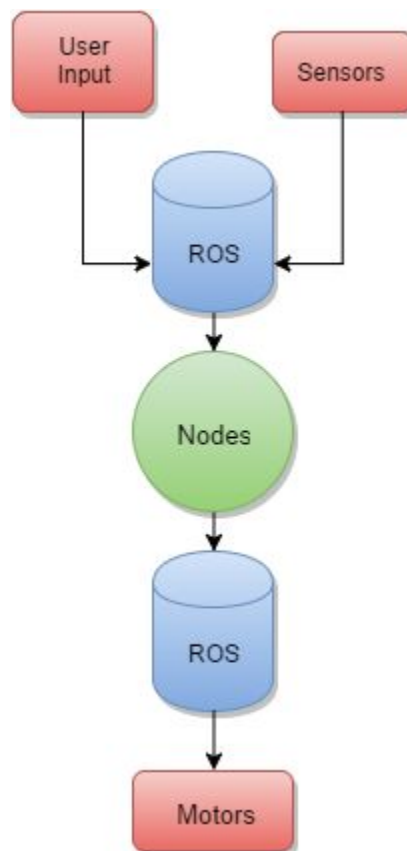

*Figure 10.6 Illustration of data flow between the hardware and software of the prototype*

### 10.3.2 Nodes

The software developed for the mine detector prototype is made of multiple nodes. The programming languages, which were used to write the executed instructions, are C++ and Python. The C++ nodes and Python nodes will be treated separately further on in this chapter.

The Python nodes are used to receive data from the turtlebot sensors and to send commands to the turtlebot motors. This is mainly because Python, being a high-level programming language[62], making it ideal for programming nodes that do not need much processing power. There are five Python nodes in the presented software handling the wheel encoder, orientation, depth sensors, Asus kinect and motors respectively. Each node will be discussed further on in this subchapter.

The C++ nodes are mainly used for processing the data received from the sensors accordingly with the mine detector algorithm. C++ being a compiled programming language takes less time and memory usage than Python which is scripted.[63],[64] This characteristic makes C++ better fitted for processing; considering that speed with which the data is processed is essential for the accuracy of the mine detector robot.

```
[INFO] [WallTime: 1449521860.021933] Covered_length= 0
[INFO] [WallTime: 1449521860.023084] Rotation= 90
[INFO] [WallTime: 1449521860.045256] Left_encoder= 52044.0
[INFO] [WallTime: 1449521860.046202] Right_encoder= 53799.0
[INFO] [WallTime: 1449521860.048381] Covered_length= 0
[INFO] [WallTime: 1449521860.049607] Rotation= 90
[INFO] [WallTime: 1449521860.059841] Left_encoder= 52140.0
[INFO] [WallTime: 1449521860.060981] Right_encoder= 53897.0
[INFO] [WallTime: 1449521860.062086] Covered_length= 0
[INFO] [WallTime: 1449521860.063323] Rotation= 135
[INFO] [WallTime: 1449521860.080044] Left_encoder= 52236.0
[INFO] [WallTime: 1449521860.081469] Right_encoder= 53994.0
[INFO] [WallTime: 1449521860.082845] Covered_length= 0
[INFO] [WallTime: 1449521860.084067] Rotation= 135
[INFO] [WallTime: 1449521860.099492] Left_encoder= 52333.0
[INFO] [WallTime: 1449521860.100282] Right_encoder= 54094.0
[INFO] [WallTime: 1449521860.101477] Covered_length= 0
[INFO] [WallTime: 1449521860.102592] Rotation= 135
[INFO] [WallTime: 1449521860.119887] Left_encoder= 52432.0
[INFO] [WallTime: 1449521860.121345] Right_encoder= 54195.0
[INFO] [WallTime: 1449521860.122755] Covered_length= 0
[INFO] [WallTime: 1449521860.123785] Rotation= 135
[INFO] [WallTime: 1449521860.140181] Left_encoder= 52532.0
[INFO] [WallTime: 1449521860.141450] Right_encoder= 54297.0
```

*Figure 10.7 Illustration of the output displayed by the encoders node while the turtlebot is moving. The current values received from the right encoder and the left encoder are displayed. After interpreting these values, the covered length and rotation, since the node has started are also shown. These values will be published for the processor node to use.*

### 10.3.3 Python Nodes

The Python nodes are receiving or sending data directly to the sensors or motors. There are five Python nodes: *Encoders*, *Orientation*, *Detection*, *Obstacle* and *Motors*.

The nodes will be written in italic.

The *Encoders* node is responsible for receiving data from the wheel encoders, to interpret the information and then send it to the topic which the processor node is subscribed to. As the wheels turn, the values, which the encoders sensors provide, are changed accordingly. By using the encoders, the distance covered by the robot can be measured. The data which the encoders provide is converted into cm. This is done inside the node. For example: If  $|a-b|=3800$ , with a being the initial value provided and b being the current value provided, means that the robot covered a 35 cm distance. The value of the covered distance will be published each time the robot has covered another 35 cm. *Figure 10.7* shows the terminal window in which the node displays the data received from the encoders and the data published on the “encoders” topic.

The orientation sensor is essential for the precision when the robot is turning. The orientation node only publishes the data received from the sensor as the raw set of data is used without further interpretation. More information about the orientation is given later in this subchapter when the robot’s rotation is discussed. *Figure 10.8* shows the terminal window in which the node displays the data received from the orientation sensors which is the same data published on the “orientation” topic.

*Figure 10.8 The orientation node is receiving data from the orientation sensors and then publishes the data for the processor node to receive.*

In order to detect the objects, which will represent the mines, the turtlebot depth sensors are used. The mines will therefore be represented as objects on the ground which will create a

height difference when the sensor are over the mine. The sensors are placed below the robot. The node, which is responsible of receiving the data from the depth sensor, is also offering an interpretation of the data. After the interpretation, the node will publish a boolean value: 0 if no mine is detected and 1 if a mine is detected. The *depth sensor* node together with the *orientation* node, *obstacle* node and *encoders* node are the sensor nodes. *Figure 10.9* shows the terminal window in which the node displays the data received from the depth sensors and the data after interpretation which will be published by the node on the “detection” topic.

```
[INFO] [WallTime: 1449530425.171011] Detect_LEFT= 1633
[INFO] [WallTime: 1449530425.172078] Detect_CENTRE= 1968
[INFO] [WallTime: 1449530425.173089] Detect_RIGHT= 1572
[INFO] [WallTime: 1449530425.174279] Void [0]
[INFO] [WallTime: 1449530425.197131] Detect_LEFT= 1634
[INFO] [WallTime: 1449530425.198688] Detect_CENTRE= 1968
[INFO] [WallTime: 1449530425.199747] Detect_RIGHT= 1572
[INFO] [WallTime: 1449530425.200758] Void [0]
[INFO] [WallTime: 1449530425.210682] Detect_LEFT= 1634
[INFO] [WallTime: 1449530425.211764] Detect_CENTRE= 2366
[INFO] [WallTime: 1449530425.212783] Detect_RIGHT= 1573
[INFO] [WallTime: 1449530425.213831] Mine detected! [1]
[INFO] [WallTime: 1449530425.231590] Detect_LEFT= 1634
[INFO] [WallTime: 1449530425.232766] Detect_CENTRE= 2366
[INFO] [WallTime: 1449530425.233648] Detect_RIGHT= 1573
[INFO] [WallTime: 1449530425.234656] Mine detected! [1]
```

*Figure 10.9* The detection node is displaying the values received from the depth sensors. After interpreting them, the node will publish the afferent boolean value: 1 for detected mine and 0 for no mine. The screenshot was taken while the robot was detecting a mine

Avoiding obstacles is possible using the data from the laser scan provided by the Asus Xtion kinect, which is mounted on the Turtlebot’s rack. Avoiding obstacles is treated in the same way as avoiding mines (explained in section 10.3), the data interpretation and the set of data which is published on the related topic is therefore similar to each other. *Figure 10.10* contains the output window of the *obstacle* node. The raw data is not displayed, as the node receives a massive set of data which has to be interpreted before publishing it.

```
[INFO] [WallTime: 1449940802.423346] Obstacle= 0
[INFO] [WallTime: 1449940802.459516] Obstacle= 0
[INFO] [WallTime: 1449940802.502277] Obstacle= 0
[INFO] [WallTime: 1449940802.541669] Obstacle= 0
[INFO] [WallTime: 1449940802.579920] Obstacle= 0
[INFO] [WallTime: 1449940802.624200] Obstacle= 0
[INFO] [WallTime: 1449940802.660208] Obstacle= 0
[INFO] [WallTime: 1449940802.664038] Obstacle= 0
[INFO] [WallTime: 1449940802.700899] Obstacle= 0
[INFO] [WallTime: 1449940802.724916] Obstacle= 0
[INFO] [WallTime: 1449940802.763769] Obstacle= 0
[INFO] [WallTime: 1449940802.806954] Obstacle= 1
[INFO] [WallTime: 1449940802.844739] Obstacle= 1
[INFO] [WallTime: 1449940802.884045] Obstacle= 1
[INFO] [WallTime: 1449940802.923958] Obstacle= 1
[INFO] [WallTime: 1449940802.935517] Obstacle= 1
[INFO] [WallTime: 1449940802.963322] Obstacle= 1
[INFO] [WallTime: 1449940802.984631] Obstacle= 1
[INFO] [WallTime: 1449940803.022764] Obstacle= 1
```

Figure 10.10: Screenshot with the data displayed by the obstacle node in the moment of an obstacle detection.

*This node works in a similar way as the detection node.*

For moving the robot around the minefield, the Turtlebot's motors are used. The motors are commanded by the motor node which publishes the angular and linear speed for the motors to receive. The speed of the motors is published accordingly to the topic which the motors node is subscribed to. The motor's node is subscribed to the "move" topic on which the processor node is publishing to. The angular and linear speed is displayed in a terminal windows as illustrated in figure 10.11.

```
[INFO] [WallTime: 1449522513.678205] Angular_speed= 0.0
[INFO] [WallTime: 1449522513.697616] Linear_speed= 0.0
[INFO] [WallTime: 1449522513.698777] Angular_speed= 0.0
[INFO] [WallTime: 1449522513.717278] Linear_speed= 0.0
[INFO] [WallTime: 1449522513.718719] Angular_speed= 0.0
[INFO] [WallTime: 1449522513.737654] Linear_speed= 0.10000000149
[INFO] [WallTime: 1449522513.738870] Angular_speed= 0.5
[INFO] [WallTime: 1449522513.757218] Linear_speed= 0.10000000149
[INFO] [WallTime: 1449522513.758412] Angular_speed= 0.5
[INFO] [WallTime: 1449522513.777417] Linear_speed= 0.10000000149
[INFO] [WallTime: 1449522513.779584] Angular_speed= 0.5
```

Figure 10.11 Data which received and published by the motors node is displayed in a terminal window while the turtlebot is turning

### 10.3.4 C++ Nodes

As mentioned earlier in this subchapter, C++ programming language was chosen to write the scripts used for processing the data received from the nodes in charge of the sensors and motors. In other words, inside the C++ node, the instructions from the Python nodes, which are related to sensors, are put together and processed, in order to have an output through the

motors. The algorithm explained earlier in this chapter (10.3) is put in practice through the node which is *precisemovedectobs*.

In order to put together all the data which comes from more than one node, the ‘processor’ node has to subscribe to multiple topics on which the sensor related nodes are publishing. To make an analogy, multiple subscription is like a human is trying to read more than one newspaper simultaneously. In order to do that, message filtering is required. In this case, the Approximate Time Policy is used, which means that the messages from the sensor nodes have to come with an almost similar time-stamp.[65]

The time-stamp is an attribute which ROS messages may apply. In this case, the messages sent between nodes are ‘PointStamped’ type which has three fields (x, y and z, float type all three) and header attributes from which the timestamp attribute is used in the presented case. The time-stamped attribute provides the precise time when the message was published. This attribute is only used by the message filter.[66]

In figure 10.12 all the nodes are presented (processor node, sensor nodes and motors node) as seen using the *rqt\_graph* software. *Rqt\_graph* provides a graphical image of data flowing between nodes through topics. This tool is very useful in the debugging process of the programming.[78]



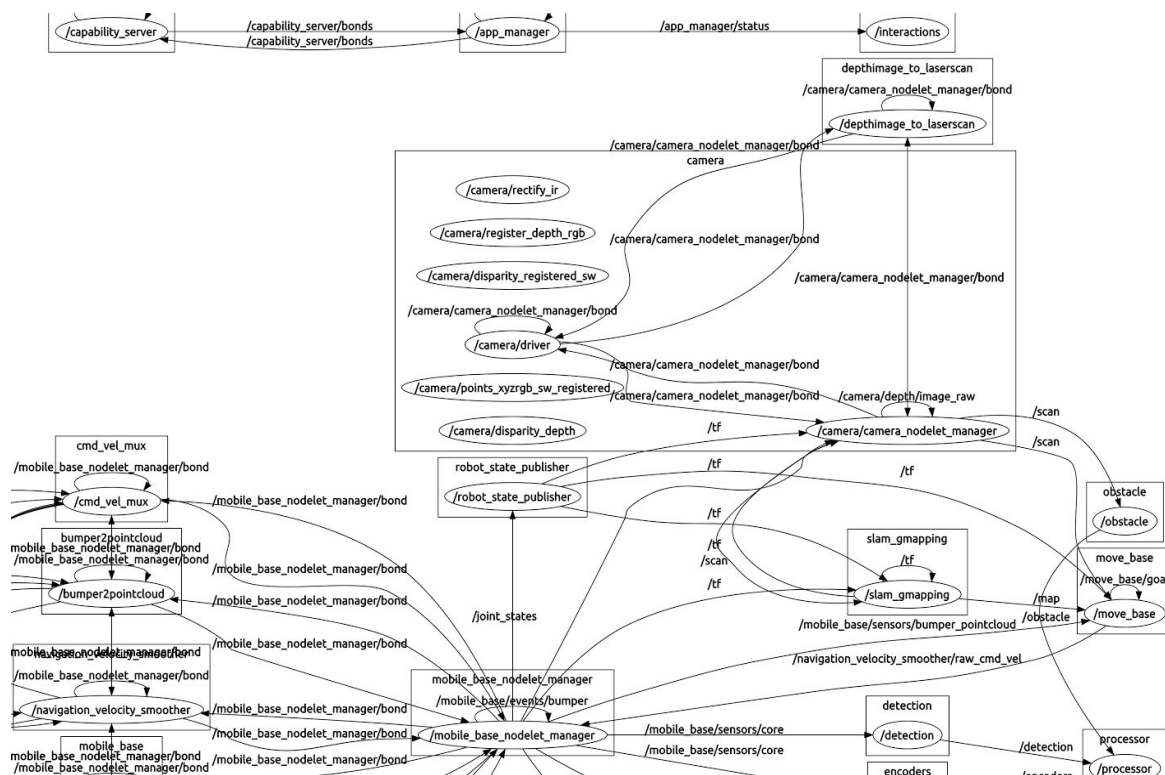

Figure 10.12: The nodes as seen in the Rqt\_graph are illustrated. The sensor nodes, motors node and processor node can be observed in the right side of the figure.

The C++ node also receives input from the user. This input is the length and the width of the minefield and the node will ask for them each time it is initialized. The location of the robot is requested as well; the user has to specify if the robot is placed in the right corner of the minefield ( if so the user will have to type in 1) or in the left one (if so the user will have to type in 0) as seen in the figure 10.13. The name of the prototype robot is Manul v 1.0.

Figure 10.13: The welcome message of the processor node is displayed. The width and length of the minefield are inserted with the value 105 (cm). The location of the robot is on the left side of the minefield as the inserted value is 0.

After initializing the ‘processor’ node, getting input with length and width and starting the message filter and the subscriptions, the node begins to call the callback function which allows the node to receive data from the topics that the nodes publish to, which are the sensor nodes in this case. The callbacks are generated using the `ros::spin` function[67]. A single spin thread is used. Considering that using the `ros::spin` function, the callback method becomes the instruction block of a loop, all the information originating from the sensor nodes is processed here in order to generate messages for the motors node accordingly to the mine detector algorithm. Each time the loop returns to its starting point, the information received from the sensor topic is refreshed.

Inside this loop, the location of the robot is known constantly and is kept in a global variable as the actions of the robot are conditioned by its location. The location based actions may be overwritten if a landmine or an obstacle is encountered. In case of an obstacle or mine, the robot will go around it through the already scanned field.

When the loop is started the robot will remember the orientation coordinates given by the orientation node. The robot will first remember the orientation coordinates being orientated forward relating to the minefield and then it will rotate 90 degrees (using the encoders, 1050 encoder units=90 degrees). As the robot is going through the minefield, it will use the orientation coordinates in order to make turns.

After the operations listed above, the mine scanner prototype will move across the minefield as described in the “Concept and operating modes” subchapter 10.2 the robot will move in a zigzag way across the minefield going around encountered mines and obstacles. In order to have a better understanding of how the robot is moving, a diagram of the robot’s movement is shown in figure 10.14.

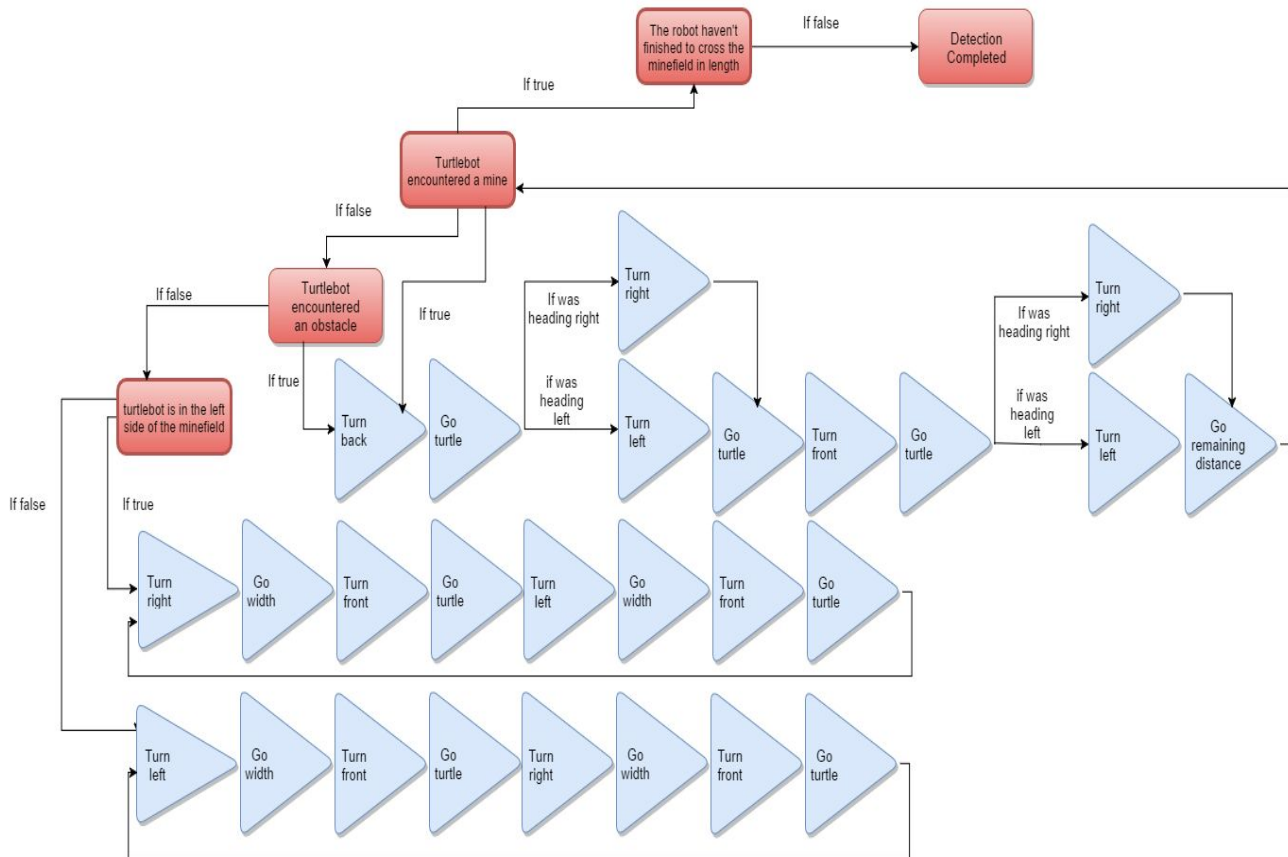

Figure 10.14: The diagram represents the way in which the C++ code is controlling the robot. The illustrated instructions are in the corp of the callback function which means that they are repeated until the node is stopped. It should be noted that “Go Turtle” means that the robot travels a distance corresponding to the length of a turtlebot, which is 35 cm.

## 10.4 How to operate the robot

Operating the robot can be performed in a few steps. Improvement on user-friendliness is ongoing as a graphical user interface, which is in the process of development.

### 10.4.1 Starting the software

To use the mine scanner prototype, the user will need an Ubuntu operated system with ROS and Turtlebot software installed. The first step to start the turtlebot is to open a terminal window where the “roslaunch turtlebot\_bringup minimal.launch” command will be executed. This will turn on the mobile base of the turtlebot and start all the necessary drivers. In a new window, the “roslaunch turtlebot\_navigation gmapping\_demo.launch” command will turn on the Asus Xtion kinect device and boot up TF in order to get the Turtlebot’s coordinates.

The second step is to open the sensor nodes and the motor nodes. The following commands have to be executed in separate terminal windows:

1. “roslaunch sense encoders.py”: will open the encoders node;
2. “roslaunch sense orientation.py”: will open the orientation node;
3. “roslaunch sense detection.py”: will open the detection node;
4. “roslaunch sense obstacle.py”: will open the obstacle node;
5. “roslaunch move lamove.py”: will open the motors node.

“roslaunch process precisemovedectobs” will open the interface

A demonstration of the prototype in action can be seen here:

<https://www.youtube.com/watch?v=7vHGHV1WdTY>

These are the python nodes which are communicating directly with the sensors mounted on the mobile base and the Asus Xtion kinect device.

The processor node will handle all the published data from the other nodes and will receive the three user inputs: length, width and the side of the minefield where the turtlebot is placed.

```

/home/turtlebot/turtlebot/src/turtlebot_apps/turtlebot_navigation/launch/gmapping_demo
[ INFO ] [1449942689.643258786]: odom received!
[ WARN ] [1449942628.309467367]: MessageFilter [target=odom ]; Dropped 98,78% of m
essages so far. Please turn the [ros.gmapping.message_notifier] roscnsole logger
to DEBUG for more information.
[ WARN ] [1449942688.309901506]: MessageFilter [target=odom ]; Dropped 95,73% of m
essages so far. Please turn the [ros.gmapping.message_notifier] roscnsole logger
to DEBUG for more information.

turtlebot@turtlebot-X200MA: ~ - 81x24
turtlebot@turtlebot-X200MA:~$ roslaunch process precisemovedectobs
Welcome to Manul v1.0 mine detector robot!

To begin, please insert the width and the length (both multiples of 35 in cm) of
the minefield you want to be scanned:
Enter the width of the field>

turtlebot@turtlebot-X200MA: ~ - 80x7
[INFO] [WallTime: 1449942795.339522] Covered length= 0
[INFO] [WallTime: 1449942795.342829] Rotation= 0
[INFO] [WallTime: 1449942795.358584] Left encoder= 45043.0
[INFO] [WallTime: 1449942795.359154] Right encoder= 28236.0
[INFO] [WallTime: 1449942795.359862] Covered length= 0
[INFO] [WallTime: 1449942795.362776] Rotation= 0

turtlebot@turtlebot-X200MA: ~ - 80x6
[INFO] [WallTime: 1449942795.361264] Orientation sensor 2= 1.0
[INFO] [WallTime: 1449942795.381591] Orientation sensor 1= 0.0
[INFO] [WallTime: 1449942795.382385] Orientation sensor 2= 1.0
[INFO] [WallTime: 1449942795.398682] Orientation sensor 1= 0.0
[INFO] [WallTime: 1449942795.399398] Orientation sensor 2= 1.0

turtlebot@turtlebot-X200MA: ~ - 80x7
[INFO] [WallTime: 1449942795.388175] Detect RIGHT= 1573
[INFO] [WallTime: 1449942795.388869] Void [0]
[INFO] [WallTime: 1449942795.397979] Detect LEFT= 1634
[INFO] [WallTime: 1449942795.398767] Detect CENTRE= 1969
[INFO] [WallTime: 1449942795.399398] Detect RIGHT= 1574
[INFO] [WallTime: 1449942795.400328] Void [0]

turtlebot@turtlebot-X200MA: ~ - 81x6
[INFO] [WallTime: 1449942795.312988] Angular_speed= 0
[INFO] [WallTime: 1449942795.352275] Linear_speed= 0
[INFO] [WallTime: 1449942795.353322] Angular_speed= 0
[INFO] [WallTime: 1449942795.393438] Linear_speed= 0
[INFO] [WallTime: 1449942795.394235] Angular_speed= 0

turtlebot@turtlebot-X200MA: ~ - 80x6
[INFO] [WallTime: 1449942795.292266] Obstacle= 0
[INFO] [WallTime: 1449942795.334084] Obstacle= 0
[INFO] [WallTime: 1449942795.345023] Obstacle= 0
[INFO] [WallTime: 1449942795.373087] Obstacle= 0
[INFO] [WallTime: 1449942795.392495] Obstacle= 0

```

Figure 10.15: Screenshot with the interface of the prototype. The two top windows are the launchers for the mobile base and Asus Xtion. The windows from the right side contain the data displayed from the encoders, orientation, detection and obstacle nodes (from top to bottom). The bottom left windows contains the data displayed by the motor's node. The middle-left window contains the interface of the processor node as it is when started up.

With all the nodes up and running, the welcome message will appear in the terminal window which is running the *processor* node (see figure 10.13). The node will wait for input of the width and the length of the minefield. The width and the length have to be a multiple of 35 in cm otherwise the input will not be accepted. Finally, the node will wait for the side of the minefield where the turtlebot is placed: 0 for left and 1 for right.

Figure 10.15 shows all the nodes running. After receiving the complete input, the processor node will command the prototype robot to begin scanning the minefield.

## 10.4.2 Scanning the minefield

While scanning the minefield, the processor node will display the current status of the robot and its current task (shown in figures 10.16, 10.17, 10.18 and 10.19).

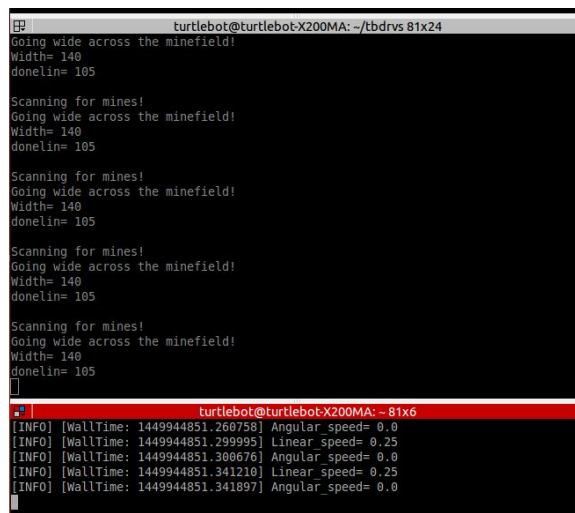

```
turtlebot@turtlebot-X200MA: ~/tbdrvs 81x24
Going wide across the minefield!
Width= 140
donelin= 105

Scanning for mines!
Going wide across the minefield!
Width= 140
donelin= 105

Scanning for mines!
Going wide across the minefield!
Width= 140
donelin= 105

Scanning for mines!
Going wide across the minefield!
Width= 140
donelin= 105

Scanning for mines!
Going wide across the minefield!
Width= 140
donelin= 105

Scanning for mines!
Going wide across the minefield!
Width= 140
donelin= 105
]

turtlebot@turtlebot-X200MA: ~ - 81x6
[INFO] [wallTime: 1449944851.260758] Angular_speed= 0.0
[INFO] [wallTime: 1449944851.299995] Linear_speed= 0.25
[INFO] [wallTime: 1449944851.300676] Angular_speed= 0.0
[INFO] [wallTime: 1449944851.341210] Linear_speed= 0.25
[INFO] [wallTime: 1449944851.341897] Angular_speed= 0.0
```

Figure 10.16 The robot is travelling across the width of the minefield. It has completed 105 cm of the 140 cm length which it has to travel to the edge of the minefield. The robot is moving with a speed of 0.25 meters per second.

```

turtlebot@turtlebot-X200MA: ~/tbdrvs 81x24
current.pos 0.763402
current.neg 0.645924

Mine encountered!!!
Turning head to the back side of the minefield!
initial.pos -0.989576
initial.neg -0.989576
current.pos 0.761538
current.neg 0.64812

Mine encountered!!!
Turning head to the back side of the minefield!
initial.pos -0.989576
initial.neg -0.989576
current.pos 0.760689
current.neg 0.649116

Mine encountered!!!
Turning head to the back side of the minefield!
initial.pos -0.989576
initial.neg -0.989576
current.pos 0.75893
current.neg 0.651172

```

```

turtlebot@turtlebot-X200MA:~$ rostopic echo /cmd_vel
[INFO] [wallTime: 1449945098.704233] Angular_speed= 0.40000000596
[INFO] [wallTime: 1449945098.743509] Linear_speed= 0.0
[INFO] [wallTime: 1449945098.744267] Angular_speed= 0.40000000596
[INFO] [wallTime: 1449945098.783545] Linear_speed= 0.0
[INFO] [wallTime: 1449945098.784265] Angular_speed= 0.40000000596

```

Figure 10.17 The robot has encountered a mine and is now proceeding to go around it. The displayed values are the goal orientation coordinates and the current orientation coordinates of the robot. The angular speed of the robot is 0.4 meters per second.

```

turtlebot@turtlebot-X200MA: ~/tbdrvs 81x24
current.pos 0.763402
current.neg 0.645924

Mine encountered!!!
Turning head to the back side of the minefield!
initial.pos -0.989576
initial.neg -0.989576
current.pos 0.761538
current.neg 0.64812

Mine encountered!!!
Turning head to the back side of the minefield!
initial.pos -0.989576
initial.neg -0.989576
current.pos 0.760689
current.neg 0.649116

Mine encountered!!!
Turning head to the back side of the minefield!
initial.pos -0.989576
initial.neg -0.989576
current.pos 0.75893
current.neg 0.651172

```

```

turtlebot@turtlebot-X200MA:~$ rostopic echo /cmd_vel
[INFO] [wallTime: 1449945098.704233] Angular_speed= 0.40000000596
[INFO] [wallTime: 1449945098.743509] Linear_speed= 0.0
[INFO] [wallTime: 1449945098.744267] Angular_speed= 0.40000000596
[INFO] [wallTime: 1449945098.783545] Linear_speed= 0.0
[INFO] [wallTime: 1449945098.784265] Angular_speed= 0.40000000596

```

Figure 10.18 The robot has encountered an obstacle and now it is proceeding to go around it. The displayed values are the goal orientation coordinates and the current orientation coordinates of the robot. The angular speed of the robot is 0.4 meters per second.

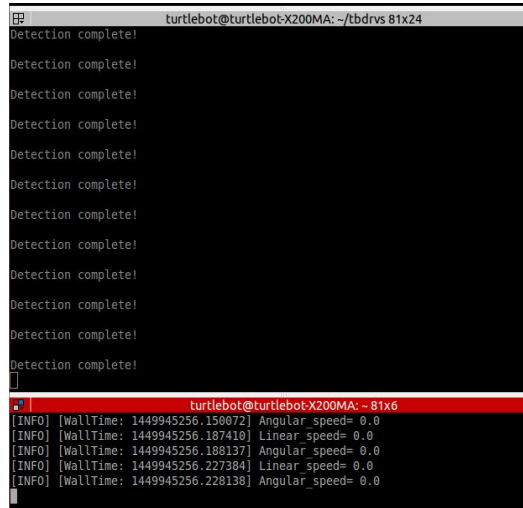

```
turtlebot@turtlebot-X200MA: ~/tbdvrs 81x24
Detection complete!
Detection complete!
Detection complete!
Detection complete!
Detection complete!
Detection complete!
Detection complete!
Detection complete!
Detection complete!
Detection complete!
Detection complete!
Detection complete!
Detection complete!
Detection complete!
Detection complete!
Detection complete!
^[[I
turtlebot@turtlebot-X200MA: ~ - 81x6
[INFO] [WallTime: 1449945256.150072] Angular_speed= 0.0
[INFO] [WallTime: 1449945256.187410] Linear_speed= 0.0
[INFO] [WallTime: 1449945256.188137] Angular_speed= 0.0
[INFO] [WallTime: 1449945256.227384] Linear_speed= 0.0
[INFO] [WallTime: 1449945256.228138] Angular_speed= 0.0
```

*Figure 10.19 The robot has finished scanning the minefield. The “Detection complete” message is displayed which means that the robot has finished*

## 10.5 Future work

*The results obtained after testing the robot are satisfying, but the project is not yet at the end of the road. Improvements and new features are being added to the prototype of the mine detection robot in order to make it faster, more precise and as user-friendly as possible.*

### 10.5.1 Mapping

Work on a mapping system which will indicate the precise locations of mines and obstacles in a fixed environment is ongoing. This will be the last of the important abilities of the mine scanner robot together with the mine detection ability and autonomous operation ability. The mapping process will be simultaneously run with the detection process, which means that the robot will have to cross over the field only once, reducing the time needed for a detection. In order for the mapping system to be complete, a technique to add the detected mines to the map is needed.

The development of an user-friendly GUI (graphical user interface) is also on the to-do list. The GUI will make the user able to see all the data the robot is receiving from sensors, and how it is processed, in one window. In case of emergency, the user will be able to take over

the command on the robot in order to avoid a danger or something similar. The map with all the detected obstacles and mines will also be present in the future GUI.

### 10.5.2 Launch file.

A launch file will be worked on, to avoid booting up 6 different nodes to get the robot running, but instead enter a few commands. This will make it easier for the user to use the robot.

## 10.6 Conclusion of the prototype

Good results were obtained following the mine detector prototype testings. The prototype is autonomous in the entire designated field. From the start of the scanning until the end of it, no human interaction is required.

At the moment, the prototype is capable of simulating the behaviour of a real landmine detection robot and will soon be able to map the exact locations of mines and obstacles on the minefield.

*This chapter covered the hardware and software components used for the prototype, along with a description of the concept, operation- and movement methods utilized by the robot in order to demonstrate the idea for the final solution described in section 9.5. These methods and areas of technology are essential in order to better understand the mine detection process presented by the prototype. A thorough explanation of the Robot Operating System(ROS) and its tools is given, which provided an overview of the complexity, diversity and function of ROS, and offered an explanation to the cooperation between software and hardware components within the operating system. Future work ideas and goals for the prototype were introduced.*



## 11. Final conclusion

Throughout history, landmines and IEDs have caused many military and civilian casualties and continue to do so. After a conflict has ended and said explosives no longer serves their purpose, these devices may, if remaining in the field, still cause unintended damage, primarily towards civilians. While IEDs take up a high percentage of all casualties, the variation in types is immense. IEDs were therefore, in this project, limited to PPIEDs. Anti-personnel mines were found to be the second highest casualty contributor in 2013, while victim-activated mines were shown to be the third highest. This is important to mention, as PPIEDs are included in the latter category. The indirect impacts can often be overlooked because of the high casualty numbers. An example could be the economical issue of landmine contamination in agricultural areas, as it limits the possibility and performance of agricultural work. In addition, being struck by a landmine may pose social, mental and economical challenges for the injured person and the person's relatives.

By using ground penetrating radars and metal detectors, the final solution will be able to detect most of the landmines and PPIEDs. If the detectors react to devices in the ground, the robot would react accordingly and create a mark on a map to indicate the presence of a mine. While driving over or stepping on a landmine would normally detonate it, this problem would be handled by using an autonomous robot based on a hovercraft, as a solution for detecting landmines and PPIEDs. The hovercraft will reduce casualties by offering a fast and precise detection process in an autonomous way, thereby simplifying the following disposal of the landmines and PPIEDs. The versatility of this solution will offer a wide array of applications, making it able to operate in many different environments. The Turtlebot as prototype is good at presenting the concept of the hovercraft, even though the final solution would require more advanced equipment.

## 12. Appendix

### 12.1 Codes

The codes for the Python nodes and for the C++ node are available on the USB flash drive attached to the report.

## 13. References and sources

[1] The Origins of Military Mines: Part I. Major William C.Schneck. Engineer Bulletin. July 1998 Available: <http://fas.org/man/dod-101/sys/land/docs/980700-schneck.html>

[2] Landmines and Unexploded Ordnance : A Resource Book  
<http://site.ebrary.com/lib/aalborguniv/detail.action?docID=2001165>

[3] J. M. Garaux, The IED fight. Marine Corps Gazette 94(1), pp. 8-12. 2010. Available:  
<http://search.proquest.com/docview/221447545?accountid=8144>.

[4] Susan G. Chesser. Afghanistan Casualties: Military Forces and Civilians. Congressional Research Service. 2012. Available: <https://www.fas.org/sgp/crs/natsec/R41084.pdf>

[5] [icasualties.org](http://icasualties.org).  
Operation enduring freedom. Accessed: 01.11.2015. Available:  
<http://icasualties.org/OEF/index.aspx>

[6] Landmine Monitor 2014.  
International Campaign to Ban Landmines – Cluster Munition Coalition  
(ICBL-CMC). ISBN: 978-2-8399-1160-3. Available:  
<http://www.the-monitor.org/media/1716915/Landmine-Monitor-2014-Web.pdf>

[7] Robert Bogue, (2011) "Detecting mines and IEDs: what are the prospects for robots?", Industrial Robot: An International Journal, Vol. 38 Iss: 5, pp.456 - 460

[8] Mineaction.org - available: <http://www.mineaction.org/programmes/afghanistan>. Accessed 14.12.2015.

[9] Explosive remnants of war. INTERNATIONAL COMMITTEE OF THE RED CROSS 2014. Available:  
<https://www.icrc.org/eng/resources/documents/publication/p0828.html>

- [10] International Campaign to ban landmines.  
<http://www.icbl.org/en-gb/the-treaty/treaty-status.aspx>.  
Accessed 14.12.2015.
- [11] Robert Keeley, 2003,  
Understanding Landmines and Mine Action.  
<http://web.mit.edu/demining/assignments/understanding-landmines.pdf>. Accessed  
14.12.2015.
- [12] Improvised Explosive  
Device: The Problem of Definition, *Studies in Conflict & Terrorism*, volume 34, Issue 9,  
2011, Paul Gill, John Horgan & Jeffrey Lovelace p.732-748
- [13] Inert Products LLC, Accessed: 17.12.2015 <http://inertproducts.com/inc/sdetail/453/5316>
- [14] Improvised Explosive Devices (IEDs) / Booby Traps, 05.07.2011,  
<http://www.globalsecurity.org/military/intro/ied.htm>. Accessed 14.12.2014
- [15] Counter-Improvised  
Explosive Device Operations, 09.01.2012, <https://info.publicintelligence.net/JCS-CIED.pdf>.  
Accessed 14.12.2015.
- [16] MŰSZAKI KATONAI KÖZLÖNY XXIII. évfolyam, 2. Szám
- [17] TNT (2,4,6-trinitrotoluene), Oxford reference, A Dictionary of Forensic Science,  
Suzanne Bell, 2013
- [18] Biological Remediation of Explosive Residues, Shree Nath Singh, 2014
- [19] ALDrone: A HUMANITARIAN DRONE FOR THE RAPID DETECTION  
OF LANDMINES AND OTHER EXPLOSIVE REMNANTS OF WAR. 2015. MENA  
Report.
- [20] Andersson Neil, Palha da Sousa Cesar, Paredes Sergio.  
Social cost of land mines in four countries: Afghanistan, Bosnia, Cambodia, and  
Mozambique BMJ 1995; 311 :718. available:  
<http://www.bmj.com.zorac.aub.aau.dk/content/311/7007/718>
- [21] Minewolf - Accessed:17.12.2015 Available:  
[http://www.minewolf.com/fileadmin/media/all/images/newsletter/MineWolf\\_Systems\\_News\\_2\\_2014\\_MW330\\_with\\_tiller\\_in\\_Somalia.jpg](http://www.minewolf.com/fileadmin/media/all/images/newsletter/MineWolf_Systems_News_2_2014_MW330_with_tiller_in_Somalia.jpg)
- [22] [http://www.minewolf.com/uploads/RTEmagicC\\_mini\\_and\\_flail\\_04.jpg.jpg](http://www.minewolf.com/uploads/RTEmagicC_mini_and_flail_04.jpg.jpg)  
Accessed 17.12.2015
- [23] Minewolf - Accessed:17.12.2015  
<http://www.minewolf.com/products/minewolf-mw370.html>

- [24] Minewolf - Accessed:17.12.2015  
<http://www.minewolf.com/products/multi-purpose-attachments/tiller.html>
- [25] Minewolf - Accessed:17.12.2015  
<http://www.minewolf.com/products/multi-purpose-attachments/flail.html>
- [26] *Robotics and Autonomous Systems*, Vol. 70, August 2015, Pages 126–144.
- [27] Minelab available Accessed: 15.12.2015:  
<http://www.minelab.com/emea/metal-detectors/countermine-detectors/f3>
- [28] Rасаq Bello, Literature Review on Landmines and Detection Methods, *Frontiers in Science*, Vol. 3 No. 1, 2013, pp. 27-42. doi: 10.5923/j.fs.20130301.05.
- [29] LANDMINE DETECTORS BASED ON NEUTRON–HYDROGEN SIGNATURES, F.D. BROOKS, A. BUFFLER and M.S. ALLIE, Department of Physics, University of Cape Town, South Africa. (IAEA Research Contract No.10987: report to RCM #2, St Petersburg, 11-14 September 2001). Available: <http://www.phy.uct.ac.za/people/buffler/Brooks%20stpete%202001.pdf>
- [30] Evaluation of PELAN as a Confirmation Sensor for Landmines and Explosives, G. Vourvopoulos, R.A. Sullivan and D.T. Holslin (Dated: June 20, 2008) Available: [http://www-pub.iaea.org/MTCD/publications/PDF/P1441\\_CD/Papers2007/vourvopoulos.pdf](http://www-pub.iaea.org/MTCD/publications/PDF/P1441_CD/Papers2007/vourvopoulos.pdf)
- [31] Landmine detection method combined with backscattering neutrons and capture gamma-rays from hydrogen, Yoshiyuki Takahashi, Tsuyoshi Misawa, Cheol Ho Pyeon, Seiji Shiroya and Kiyoshi Yoshikawa, 2011. Available: <http://www.sciencedirect.com/science/article/pii/S0969804311000108>
- [32] Neutron and neutron-induced gamma ray signatures as a template matching technique for explosives detection. Rebecca L. Brewer 2005. Available: <https://krex.k-state.edu/dspace/bitstream/handle/2097/2230/RebeccaBrewer2009.pdf;jsessionid=0FF92D53E90E642FF06613957FFC3794?sequence=3>
- [33] A. Poling, B. Weetjens, C. Cox, N. W. Beyene, H. Bach and A. Sully. USING TRAINED POUCHED RATS TO DETECT LAND MINES: ANOTHER VICTORY FOR OPERANT CONDITIONING. *J. Appl. Behav. Anal.* 44(2), pp. 351-5. 2011.
- [34] Transgenic Arabidopsis thaliana for detection of explosives in the soil. Aresa Biodetection ApS, Daughter company of Aresa A/S. Available: [http://gmoinfo.jrc.ec.europa.eu/gmp\\_report.aspx?CurNot=B/DK/06/01](http://gmoinfo.jrc.ec.europa.eu/gmp_report.aspx?CurNot=B/DK/06/01)

[35] Joel Miller & Geoffrey Barrall, Explosives Detection with Nuclear Quadrupole Resonance, *American Scientist*, Vol. 3 No. 1, 2005, pp. 50. DOI: [10.1511/2005.1.50](https://doi.org/10.1511/2005.1.50)

[36] Alternatives For Landmine Detection MacDonald, Jacqueline ; Lockwood, J. R. ; McFee, John ; Altshuler, Thomas ; Broach, Thomas, 2003.

Available:

<http://oai.dtic.mil/oai/oai?verb=getRecord&metadataPrefix=html&identifier=ADA413772>

[37] Geneva International Centre for Humanitarian Demining.

Available: <http://www.gichd.org/mine-action-topics/standards/international-standards/>

Accessed 15-12-2015

[38] Mechanical demining IMAS 09.50, First edition, 12 october 2006. Available:

<http://www.mineactionstandards.org/fileadmin/MAS/documents/imas-international-standards/english/series-09/IMAS-09-50-Ed1-Am4.pdf>

[39] Guide to the procurement of mine action equipment IMAS

03.10, First edition, 01 January 2003. Available:

<http://www.mineactionstandards.org/fileadmin/MAS/documents/imas-international-standards/english/series-03/IMAS-03-10-Ed1-Am6.pdf>

[40] Droner ApS. Accessed: 17.12.2015 available: <http://droner.dk/>

[41] Jacobs, W.(2006). hovercraft. In *The Oxford Companion to Ships and the Sea*. Oxford University Press. Retrieved 24 Nov. 2015, from

<http://www.oxfordreference.com/view/10.1093/acref/9780199205684.001.0001/acref-9780199205684-e-1278>.

[42] Renegade Hovercraft, <http://www.renegadehovercraft.com/renegade-turnkey-iq.html>,

Accessed 24.11.2015

[43] Wikimedia.org, available:

[https://commons.wikimedia.org/wiki/File:Hovercraft\\_-\\_scheme.svg#/media/File:Hovercraft\\_-\\_scheme.svg](https://commons.wikimedia.org/wiki/File:Hovercraft_-_scheme.svg#/media/File:Hovercraft_-_scheme.svg) Accessed 16.12.2015

[44] The Hovercraft Homepage, Alex Olshove, Hovercraft FAQ.

[www.hovercrafthomepage.blogspot.dk](http://www.hovercrafthomepage.blogspot.dk)

<http://hovercrafthomepage.blogspot.dk/2010/02/hovercraft-faq.html>.

Accessed 09.12.2015

[45] How a hovercraft works, [www.Discoverhover.org](http://www.Discoverhover.org),

<http://www.discoverhover.org/abouthovercraft/works.htm>

Accessed: 16.12.2015

[46] DiscoverHover. <http://www.discoverhover.org/abouthovercraft/faq.html>

Accessed 25.11.2015

- [47] Sandwich technology. [www.diabgroup.com](http://www.diabgroup.com)  
<http://www.diabgroup.com/en-GB/Knowledge/Sandwich-technology>  
Accessed 11.12.2015.
- [48] Universal Hovercraft. UH - Electric Hovercraft. [www.hovercraft.com](http://www.hovercraft.com)  
[http://hovercraft.com/content/index.php?main\\_page=index&cPath=1\\_30\\_247](http://hovercraft.com/content/index.php?main_page=index&cPath=1_30_247)  
Accessed 25.11.2015
- [49] Neoteric Hovercraft, Inc. Available:<https://neoterichovercraft.com/index.htm> Accesses:  
12.15.2015
- [50] HOVERCRAFTmodels. available:  
<http://www.hovercraftmodels.com/store/contents/en-us/d1.html> Accessed: 12.15.2015
- [51] Light Hovercraft Design, Christopher Fitzgerald, Robert Wilson. Hoverclub of America.  
1995.
- [52] Turtlebot 2, [www.clearpathrobotics.com](http://www.clearpathrobotics.com) , <http://www.clearpathrobotics.com/turtlebot-2/>  
Accessed: 16.12.2015
- [53] Kobuki Spec, Gaitech, [www.gaitech.hk](http://www.gaitech.hk)  
[http://www.gaitech.hk/wp-content/uploads/2014/06/kobuki\\_spec.jpg](http://www.gaitech.hk/wp-content/uploads/2014/06/kobuki_spec.jpg) Accessed: 16.12.2015
- [54] Asus Xtion Pro Live brings more Kinect-like goodness to the world, Edwin Kee,  
[www.ubergizmo.com](http://www.ubergizmo.com)  
<http://cdn2.ubergizmo.com/wp-content/uploads/2011/07/asus-xtion-pro-live.jpg> Accessed:  
16.12.2015
- [55] Ramsden,Edward. 2006. Hall-Effect Sensors : Theory and Application (2nd Edition).  
Burlington, MA, USA: Newnes. Accessed December 14, 2015. ProQuest ebrary.
- [56] Elisabeth Eitel, May 7 2014: Basics of rotary encoders: Overview and new technologies  
<http://machinedesign.com/sensors/basics-rotary-encoders-overview-and-new-technologies-0>
- [57] Asus XTION PRO LIVE/B/U USB 2.0 and USB 3.0 RGB and DepthSensor, newegg,  
[www.newegg.com](http://www.newegg.com) :<http://www.newegg.com/Product/Product.aspx?Item=N82E16826785030>  
Accessed: 16.12.2015
- [58] ASUS X200MA-SCL0505F 11.6-Inch Touchscreen Laptop/Intel Celeron N2840/4GB  
memory/500GB HDD/Win 8.1 (Black), ASUS, [www.amazon.com](http://www.amazon.com)  
[http://www.amazon.com/X200MA-SCL0505F-11-6-Inch-Touchscreen-Laptop-Celeron/dp/B00Y021M4M/ref=sr\\_1\\_13?ie=UTF8&qid=1450309224&sr=8-13&keywords=asus+x200m](http://www.amazon.com/X200MA-SCL0505F-11-6-Inch-Touchscreen-Laptop-Celeron/dp/B00Y021M4M/ref=sr_1_13?ie=UTF8&qid=1450309224&sr=8-13&keywords=asus+x200m)  
Accessed: 16.12.2015
- [59] Turtlebot2, [www.arobose.com](http://www.arobose.com) <http://www.arobose.com/shop/67-gamme-turtlebot-2>  
Accessed: 16.12.2015

- [60] Introduction, DirkThomas, [www.wiki.ros.org](http://www.wiki.ros.org), <http://wiki.ros.org/ROS/Introduction>, Accessed: 16.12.2015
- [61] Writing a Simple Publisher and Subscriber (C++), WilliamWoodall, [www.wiki.ros.org](http://www.wiki.ros.org), [http://wiki.ros.org/ROS/Tutorials/WritingPublisherSubscriber\(c%2B%2B\)](http://wiki.ros.org/ROS/Tutorials/WritingPublisherSubscriber(c%2B%2B)) Accessed: 16.12.2015
- [62] ROS Concepts, AaronMR, [www.wiki.ros.org](http://www.wiki.ros.org), <http://wiki.ros.org/ROS/Concepts> Accessed: 16.12.2015
- [63] General Python FAQ, <https://docs.python.org/2/faq/general.html#what-is-python-good-for> Accessed: 16.12.2015
- [64] Yet Another Language Speed Test: Counting Primes, BJ PELC, <https://bjpelc.wordpress.com>  
<https://bjpelc.wordpress.com/2015/01/10/yet-another-language-speed-test-counting-primes-c-c-java-javascript-php-python-and-ruby-2/> Accessed: 16.12.2015
- [65] message\_filters, DavidGossow, [www.wiki.ros.org](http://www.wiki.ros.org)  
[http://wiki.ros.org/message\\_filters?distro=hydro#ApproximateTime\\_Policy](http://wiki.ros.org/message_filters?distro=hydro#ApproximateTime_Policy) Accessed: 16.12.2015
- [66] geometry\_msgs/PointStamped Message, [www.docs.ros.org](http://www.docs.ros.org)  
[http://docs.ros.org/api/geometry\\_msgs/html/msg/PointStamped.html](http://docs.ros.org/api/geometry_msgs/html/msg/PointStamped.html) Accessed: 16.12.2015
- [67] rqt\_graph, DarioushForouher, [www.wiki.ros.org](http://www.wiki.ros.org), [http://wiki.ros.org/rqt\\_graph](http://wiki.ros.org/rqt_graph) Accessed: 16.12.2015